

TAYLOR STUDWELDING SYSTEMS LIMITED



OPERATING GUIDE

FOR TYPES

DA4, DA5 & DA6

HI-LIFT

DRAWN ARC PISTOL

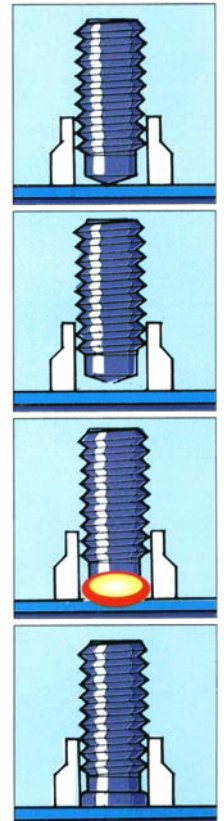

A TAYLORMADE DRAWN ARC STUDWELDING PISTOL

INDEX

PAGE No. CONTENT

3	USEFUL INFORMATION.
5	IMPORTANT SAFETY INFORMATION.
7	INTRODUCTION TO STUDWELDING.
8	SETTING UP AND WELDING.
11	EXPLODED DIAGRAMS AND PARTS LISTINGS.
18	ACCESSORIES.
21	EC DECLARATION OF CONFORMITY.

USEFUL INFORMATION

MANUFACTURERS DETAILS

TAYLOR STUDWELDING SYSTEMS LIMITED
COMMERCIAL ROAD
DEWSBURY
WEST YORKSHIRE
WF13 2BD
ENGLAND

TELEPHONE : +44 (0)1924 452123
FACSIMILE : +44 (0)1924 430059
email : sales@taylor-studwelding.com
WEB : www.taylor-studwelding.com

SALES DIRECT TEL : +44 (0)1924 487703
TECHNICAL HELPLINE : +44 (0)1924 487701

You may wish to record the details of your controller below as this information will help with any technical assistance you may require:

PISTOL SERIAL No.	
DATE PURCHASED.	

PURPOSE AND CONTENT OF THIS GUIDE

This guide has been written for :

- The personnel of the end-user responsible for the installation and maintenance of the pistol.
- The operator of the welding pistol.

This guide contains information relating to :

- Installation and connection.
- Operation.
- Technical specifications and parameters.
- Spare parts.

USEFUL INFORMATION

FURTHER INFORMATION

Should you require additional technical information, please contact us directly (details on previous page) or our local agent / distributor (details of agents etc. can be obtained from us).

This guide contains important information which is a pre-requisite for safe Operation of the equipment. The operating personnel must be able to consult this guide when necessary. In the interests of safety, make this guide available to your personnel in good time.

If the equipment is sold / passed on, please hand over this manual to the new owner and if possible please inform us of the name and address of the new owner, in case we need to contact him regarding the safety of the machine.



PLEASE READ THIS GUIDE CAREFULLY BEFORE INSTALLING OR OPERATING THE PISTOL.



PLEASE OBSERVE CAREFULLY ALL SAFETY PROCEDURES/INSTRUCTIONS.



DUE TO THE POWER REQUIREMENTS AND ELECTROMAGNETIC EMISSIONS PRODUCED DURING NORMAL USE, THIS PISTOL MUST ONLY BE OPERATED IN AN INDUSTRIAL ENVIRONMENT.



NEVER REMOVE ANY PORTION OF THE PISTOL HOUSING WITHOUT FIRST ISOLATING THE PISTOL FROM THE CONTROLLER.

IMPORTANT SAFETY INFORMATION !

PROTECT YOURSELF AND OTHERS !

Read and understand these safety notes.

ELECTRICAL

No portion of the outer cover of the welding controller should be removed by anyone other than suitably qualified personnel and never whilst mains power is connected.



ALWAYS DISCONNECT THE MAINS LEAD BEFORE ATTEMPTING ANY MAINTENANCE.

BEWARE - RISK OF ELECTRIC SHOCK !

Do not use any fluids to clean electrical components as these may penetrate into the electrical system.

Installation must be according to the setting up procedure detailed on page 8 of this guide and must be in line with national, regional and local safety codes.

FIRE

During welding small particles of very hot metal are expelled. Ensure that no combustible materials can be ignited by these.

PERSONNEL SAFETY

Arc rays can burn your eyes and skin and noise can damage your hearing. Operators and personnel working in close proximity must wear suitable eye, ear and body protection.

Fumes and gases can seriously harm your health. Use the equipment only in a suitably ventilated area. If ventilation is inadequate, then appropriate fume extraction equipment must be used.

Hot metal spatter can cause fire and burns. Appropriate clothing must be worn. Clothing made from, or soiled with, combustible materials must NOT be worn.

Have a fire extinguisher nearby and know how to use it.

Magnetic fields from high currents can affect heart pacemakers or other electronically controlled medical devices. It is imperative that all personnel likely to come into the vicinity of any welding plant are warned of the possible risks before entering the area.

MAINTENANCE

All cables must be inspected regularly to ensure that no danger exists from worn or damaged insulation or from unsound electrical connections. Special note should be made of the cables close to the pistol, where maximum wear occurs. As well as producing inconsistent welds, worn cables can overheat or spark, giving rise to the risk of fire.

IMPORTANT SAFETY INFORMATION !

5. TRAINING

Use of the equipment must be limited to authorised personnel only who must be suitably trained and must have read and understood this manual. This manual must be made available to all operators at all times. Further copies of this manual may be purchased from the manufacturer. Measures must be taken to prevent the use of this equipment by unauthorised personnel.

6. INSTALLATION

Ensure that the site chosen for the equipment is able to support the weight of the equipment and that it will not fall or cause a danger in the course of its normal operation. Do not hang connecting cables over sharp edges and do not install connecting cables near heat sources or via traffic routes where people may trip over them or they may be damaged by the passage of vehicles (forklifts etc).

7. INTERFERENCE

During welding operations, intense magnetic and electrical fields are unavoidably produced and these may interfere with other sensitive Electronic equipment.

As previously mentioned, all personnel wearing heart pacemakers or other electronically controlled medical devices must be kept well away from any welding operations.

The welding equipment should be installed at least 5 metres away from any computer equipment to minimise any possible interaction. Note that cables carrying signals between electronic devices are also capable of picking up interference which may modify the way in which those devices function and therefore should be sited outside the 5 metre zone.

Do not place objects which are sensitive to magnetism near the welding area, wristwatches, credit cards, computer disks etc. will all be rendered useless.

The welding equipment, like all other welding equipment, is itself electronically sensitive and its position relative to other radiation emitting equipment (mobile phones, remote controls, motor speed controllers etc.) must be considered.

8. DISPOSAL

The equipment either wholly or any of its component parts may be disposed of as part of general industrial waste or passed to a scrap merchant. None of the components used in the manufacture are toxic, carcinogenic or harmful to health in their "as supplied" condition.

INTRODUCTION TO STUDWELDING

The Taylor Studwelding DA6 HI-LIFT studwelding pistol when matched with an appropriate controller and earth cables is intended for accurate stud welding up to 30 mm diameter studs. The pistol is lightweight, ergonomic and has been designed to operate with a minimum amount of maintenance. The DA6 HI-LIFT has been specifically designed to have an increased lift capacity especially when welding with increased protrusion e.g. When welding shear connectors (concrete anchors) thru-deck.

The energy required to carry out the welding operation is derived from an appropriate studwelding controller.

Taylor Studwelding Systems Ltd controllers are modern, robustly designed and offer maximum reliability combined with an easy to understand operator interface.

THE PROCESS

The process of drawn arc studwelding is long established and well proven. The basic steps are as follows :

- A measured amount of weld stud protrusion is set at the welding pistol.
- Once in position, the pistol lifts the stud away from the work-piece, simultaneously striking an arc between the two.
- Both the tip of the weld stud and the surface of the work-piece melt as the arc is sustained for a pre-determined interval.
- At the completion of the pre-determined interval, the pistol returns the weld stud to the molten pool on the work-piece, thus forming a weld.

The most common and traditional drawn arc welds have a weld duration greater than 100ms and employ the use of a single use ceramic arc shield, commonly referred to as a ferrule. This ferrule helps to protect the arc during the weld and assists in formation of the final fillet. Post welding the ferrule is removed and disposed of.

SETTING UP AND WELDING

Select the type and size of stud you wish to weld and obtain the correct chuck and foot arrangement (see below and the accessories section of this guide for a list of available sizes).

Standard shear connector chucks screw directly onto the thread on the pistol shaft. The chucks normally have a cross drilled hole in order that a bar can be inserted for tightening or have machined flats to take a wrench.



IMPORTANT! Make sure the chuck is fitted securely. Failure to do so may result in damage to both the chuck and the pistol shaft during welding.

IMPORTANT! Ensure that when fitting the chuck that the cable attachment to the shaft is not loosened, as this also may result in damage during welding.

An assortment of front end options are available (see fig.1 - 3 right) and which of these would be preferable is down to customer choice when ordering. All three options shown perform the same task but are better suited to particular applications.

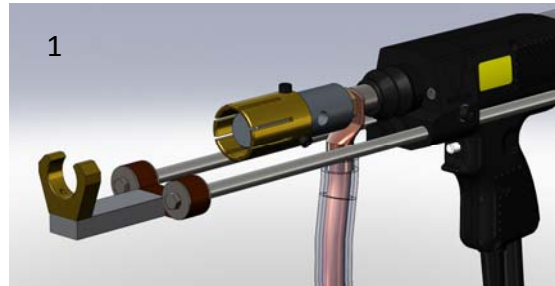

Fig.1 shows an extended foot arrangement which is favoured by many when performing thru-deck welding. This foot arrangement allows studs and ferrules to be placed in areas with limited access.

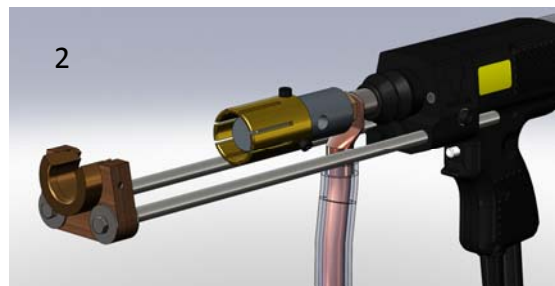

Fig.2 shows an arrangement more suited in “to beam” welding where conditions and access are generally easier.

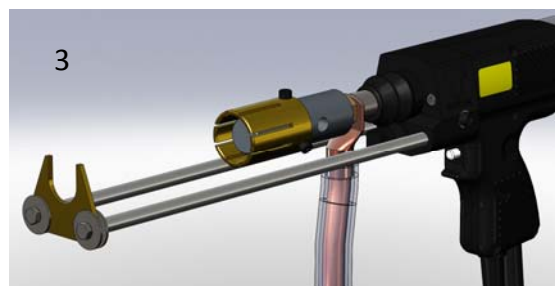

Fig.3 shows a budget arrangement which is available for lower volume work.

This pistol is commonly referred to as a “ring lift” pistol. This is because the lift mechanism in the pistol includes a clutch assembly with a tilting ring. What this means in practical terms is that not only can the lift can be adjusted within its operational limits, should certain parameters change from weld to weld, for example the studs being welded varying in length slightly, the pistol will be able to allow for this without affecting the lift that has been set. Even so, we recommend that only properly manufactured weld studs be used to ensure repeatable weld quality.

SETTING UP AND WELDING

Fit the stud and ferrule in place and set the required burn off protrusion. This is achieved by using a 5mm hex key to loosen the leg clamps in the front end cap.

After loosening the clamps, slide the legs in or out until the desired stud protrusion is achieved (this amount will vary from stud size to stud size and is generally proportional to the stud diameter).

NOTE! In the BS EN ISO standard covering the manufacture of drawn arc weld studs, the length prior to welding (this is the length after welding plus the burn off allowance) is at the discretion of the stud manufacturer.

Differences in this length would impact on the burn off protrusion value.

As a general rule of thumb, we would suggest that the burn off protrusion distance should be approximately 8 to 10mm, but never less than 7mm.

Once the correct protrusion is set, you must ensure that the movement of the stud inside the ferrule is smooth, as any binding between the stud and ferrule will result in poor or bad welds. As can be seen in the accompanying illustration where the foot piece is shown with some of the fasteners missing, the holes in the foot piece are a lot bigger than the screws fastening the foot piece to the legs. This allows the foot piece to be adjusted to remove any binding between the stud and ferrule. Once these conditions are satisfied, you are now ready to set the lift.

IMPORTANT!

It is necessary to check/reset the protrusion and positioning of the foot adaptor when changing stud lengths/diameters.

SETTING THE LIFT

Adjustment of the pistol lift is achieved by removing the rear end cap of the pistol. Inside is an adjuster with a large slot. Use a coin to twist the adjuster. Clockwise rotation reduces lift and conversely anti-clockwise rotation increases lift. The adjuster has a “click” detent, each click is approximately equal to a 0.25mm change in lift.

Lift should be set between 1mm and 8mm depending on the size of stud being welded and other application specific factors e.g. material, site conditions etc.

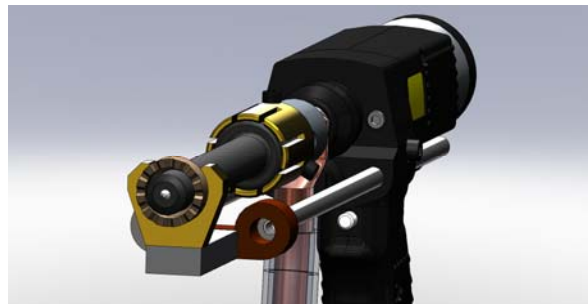
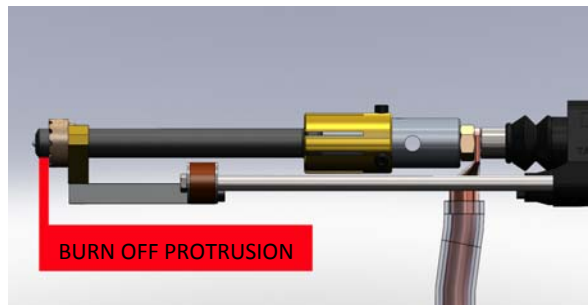
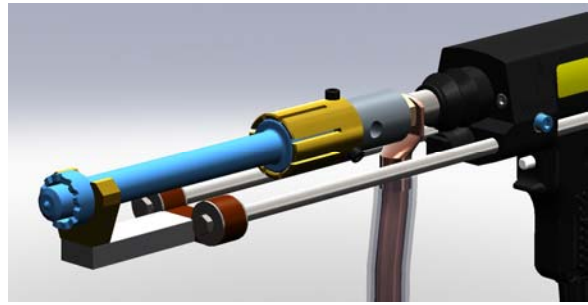

SETTING UP AND WELDING

Once the required lift has been set, the pistol is now ready to weld and can be connected to the controller. Consult your appropriate controller operating guide for assistance in setting up the controller.

Other useful information including stud welding techniques, weld testing and inspection can also be found in the controller operating guide.

PLEASE NOTE. Information contained in this operating guide is intended to assist in setting up and using the pistol. All the suggested settings are intended as a starting point only. Fine tuning the settings to achieve the most satisfactory results is essential and is the responsibility of the user of the pistol.

EXPLODED DIAGRAMS & PARTS LISTINGS

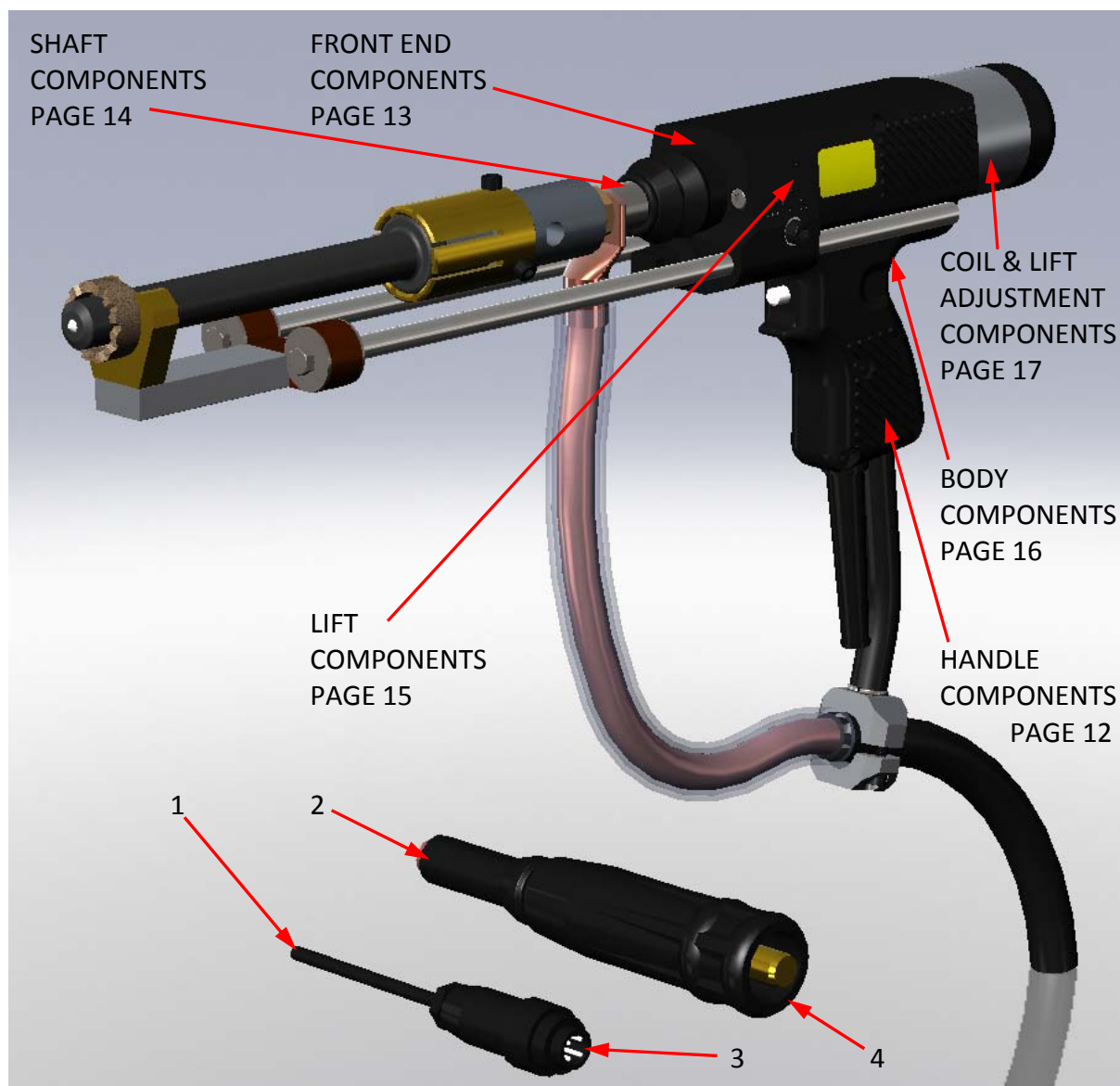

ITEM	No. OFF	PART No.	DESCRIPTION
1	3	71-300-009	4 CORE CONTROL CABLE (m)
2	3	71-300-015	120mm ² WELDING CABLE (m) - DA6
or	3	71-300-006	95mm ² WELDING CABLE (m) - DA5
or	3	71-300-005	70mm ² WELDING CABLE (m) - DA4
3	1	71-101-030	4 PIN CONTROL PLUG
4	1	81-101-163	WELDING PLUG - DA6
or	1	81-101-149	WELDING PLUG - DA4 & DA5
5	5	71-101-032	CABLE CLIP (NOT SHOWN)

EXPLODED DIAGRAMS & PARTS LISTINGS

ITEM	QTY	PART No.	DESCRIPTION
1	1	81-101-031	SWITCH
2	1	81-101-401	SLING SHAFT
3	2	Z200-03-016	SCREW
4	1	Z305-14-012	SCREW
5	1	81-101-045	HANDLE COVER

ITEM	QTY	PART No.	DESCRIPTION
6	1	Z120-05-025	SCREW
7	2	Z120-05-020	SCREW
8	1	81-101-125	PUSHBUTTON
9	1	81-101-030	SPRING
10	1	81-101-089	ACTUATOR
11	1	81-101-054	CABLE SLEEVE
12	1	Z615-10-000	WASHER
13	1	81-101-205	CABLE MOUNT
14	1	Z120-10-030	SCREW
15	1	81-101-204	CABLE CLAMP
16	2	Z615-05-000	WASHER
17	2	Z100-05-020	SCREW

EXPLODED DIAGRAMS & PARTS LISTINGS

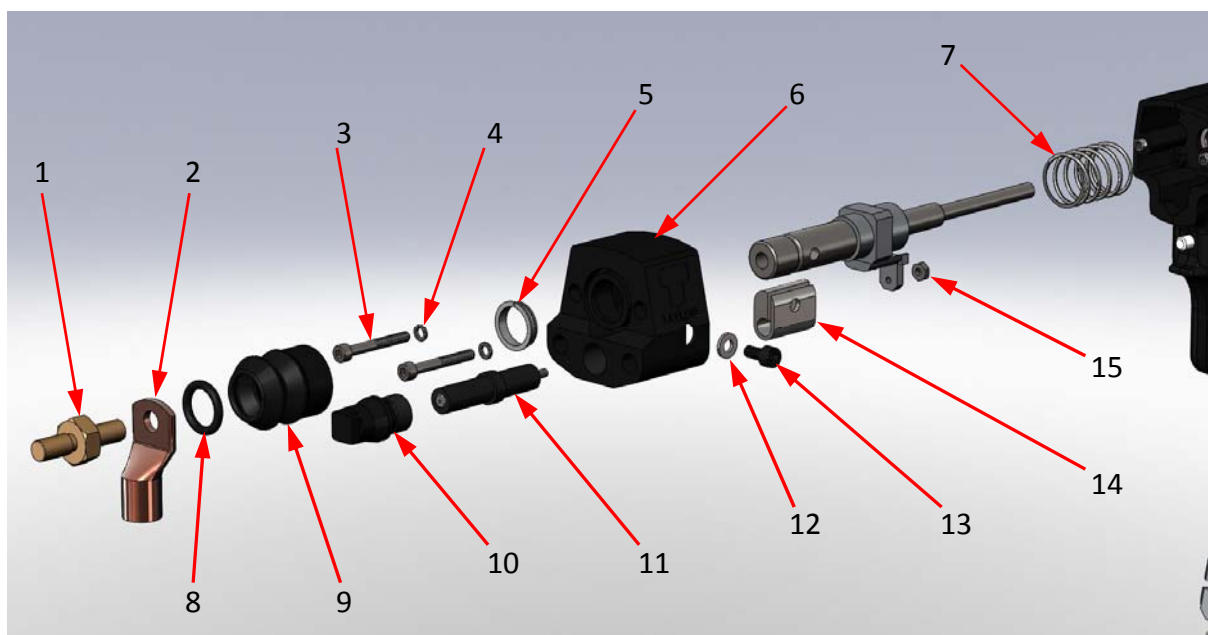

ITEM	No. OFF	PART No.	DESCRIPTION
1	1	81-101-201	CHUCK ADAPTOR
2	1	Z700-10-095	TERMINAL - DA5 & DA6
or	1	Z700-10-070	TERMINAL - DA4
3	2	Z105-05-035	SCREW
4	2	Z615-05-000	WASHER
5	1	81-111-052	CLIP BEARING
6	1	81-101-399	FRONT END CAP
7	1	81-101-398	SPRING
8	1	81-101-168	O RING
9	1	81-101-006	BELLOWS
10	1	81-101-212	DAMPER CAP
11	1	81-111-054	DAMPER
12	2	Z600-06-000	WASHER
13	2	Z100-06-012	SCREW
14	2	81-101-387	LEG GRIP INSERT
15	1	Z505-10-032	NUT



EXPLODED DIAGRAMS & PARTS LISTINGS

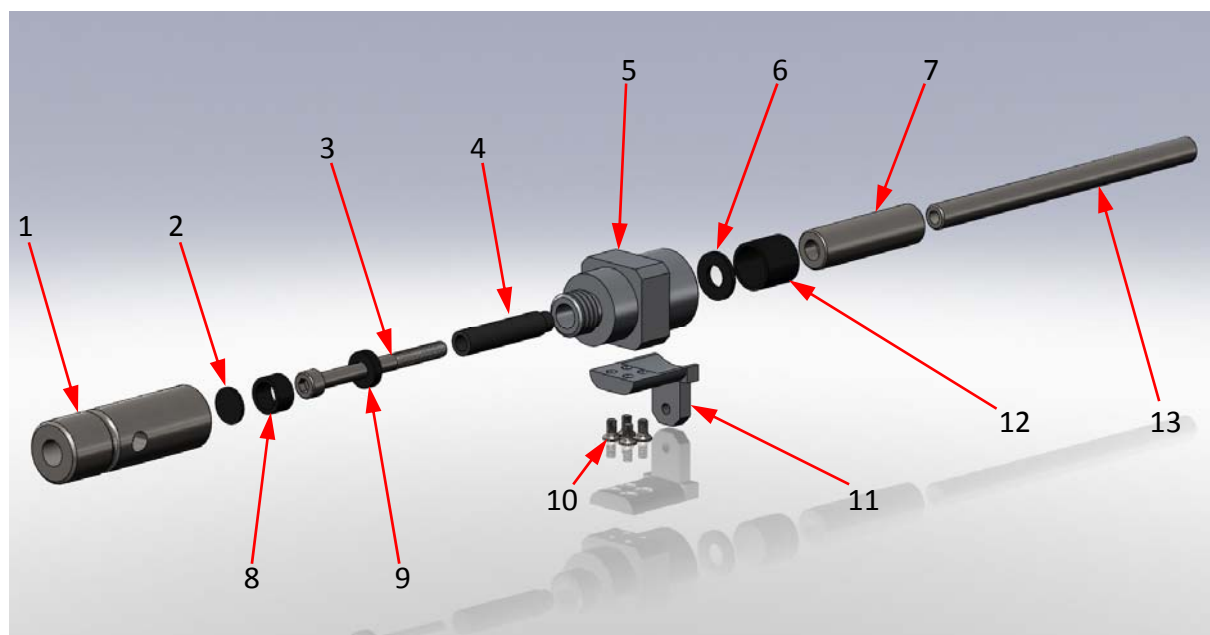

COMPLETE SHAFT IS AVAILABLE UNDER PART NUMBER : 81-101-400

ITEM	No. OFF	PART No.	DESCRIPTION
1	1	81-101-208	SHAFT FRONT
2	1	81-101-065	INSULATOR
3	1	Z105-05-055	SCREW
4	1	81-101-391	INSULATOR
5	1	81-101-394	SHAFT BLOCK
6	1	81-101-071	INSULATOR
7	1	81-101-073	LIFTING SLEEVE
8	1	81-101-066	INSULATOR
9	1	81-101-068	INSULATOR
10	4	Z205-03-008	SCREW
11	1	81-101-392	DAMPER BRACKET
12	1	81-101-072	INSULATOR
13	1	81-101-396	GUIDE SHAFT



EXPLODED DIAGRAMS & PARTS LISTINGS

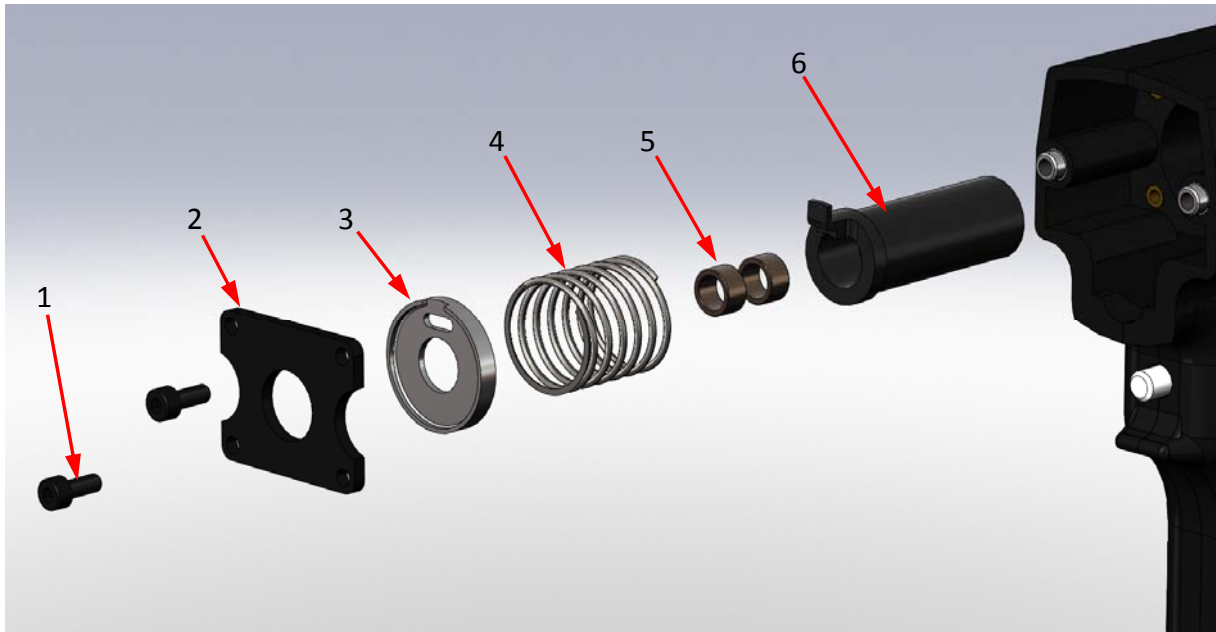

ITEM	No. OFF	PART No.	DESCRIPTION
1	4	Z220-04-010	SCREW
2	1	81-101-014	RETAINING PLATE
3	1	81-101-015	LIFTING RING
4	1	81-101-018	SPRING
5	2	81-101-250	BEARING BUSH
6	1	81-101-395	LIFTING HOOK



EXPLODED DIAGRAMS & PARTS LISTINGS

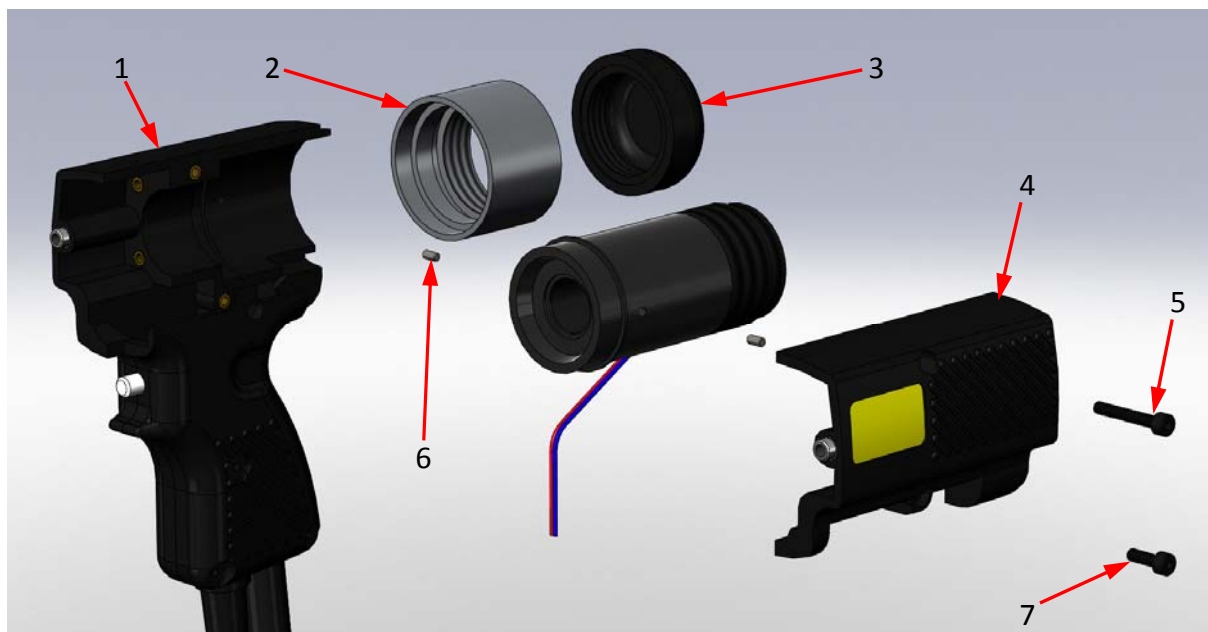

ITEM	No. OFF	PART No.	DESCRIPTION
1	1	81-101-023	PISTOL HALF MOULDING
2	1	81-101-397	BODY CLAMPING RING
3	1	81-101-101	REAR END CAP
4	1	81-101-024	PISTOL HALF MOULDING
5	1	Z100-04-025	SCREW
6	2	81-101-255	PIN
7	1	Z100-04-016	SCREW



EXPLODED DIAGRAMS & PARTS LISTINGS

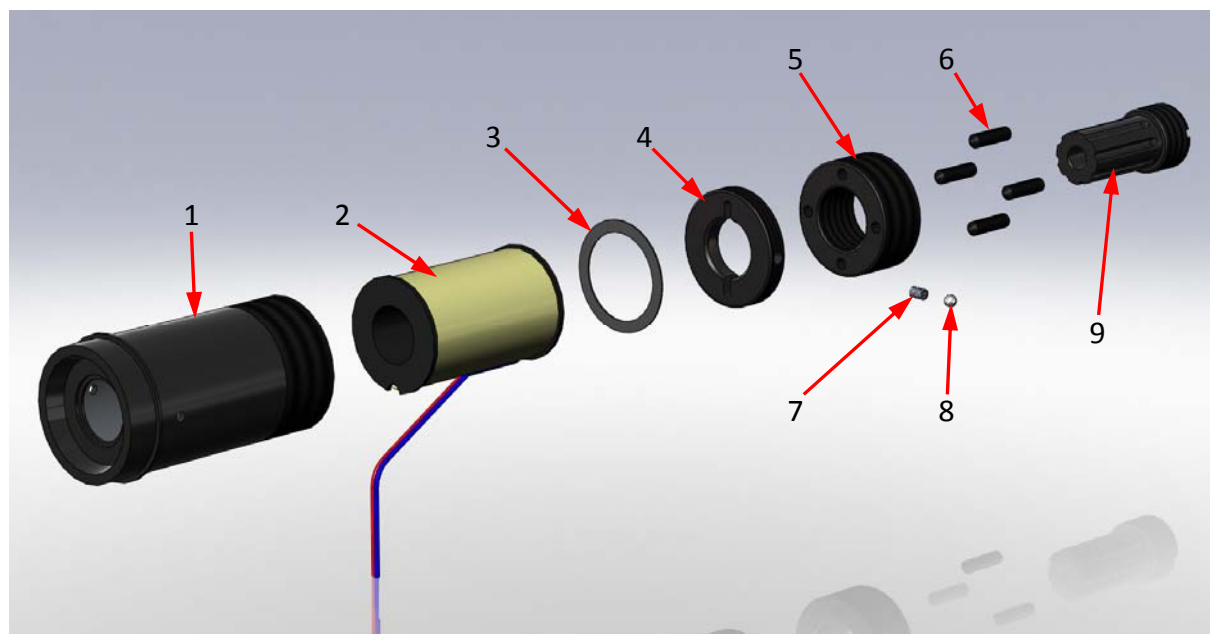

ITEM	No. OFF	PART No.	DESCRIPTION
1	1	81-101-390	COIL HOUSING
2	1	81-101-389	LIFT COIL
3	1	81-101-039	WAVE SPRING
4	1	81-101-043	DETENT HOUSING
5	1	81-101-104	COIL LOCKING RING
6	4	Z410-05-020	SET SCREW
7	1	81-101-083	SPRING
8	1	81-101-082	DETENT BALL
9	1	81-101-393	BACKSTOP



ACCESSORIES - BUDGET FOOT ASSEMBLY & CHUCKS

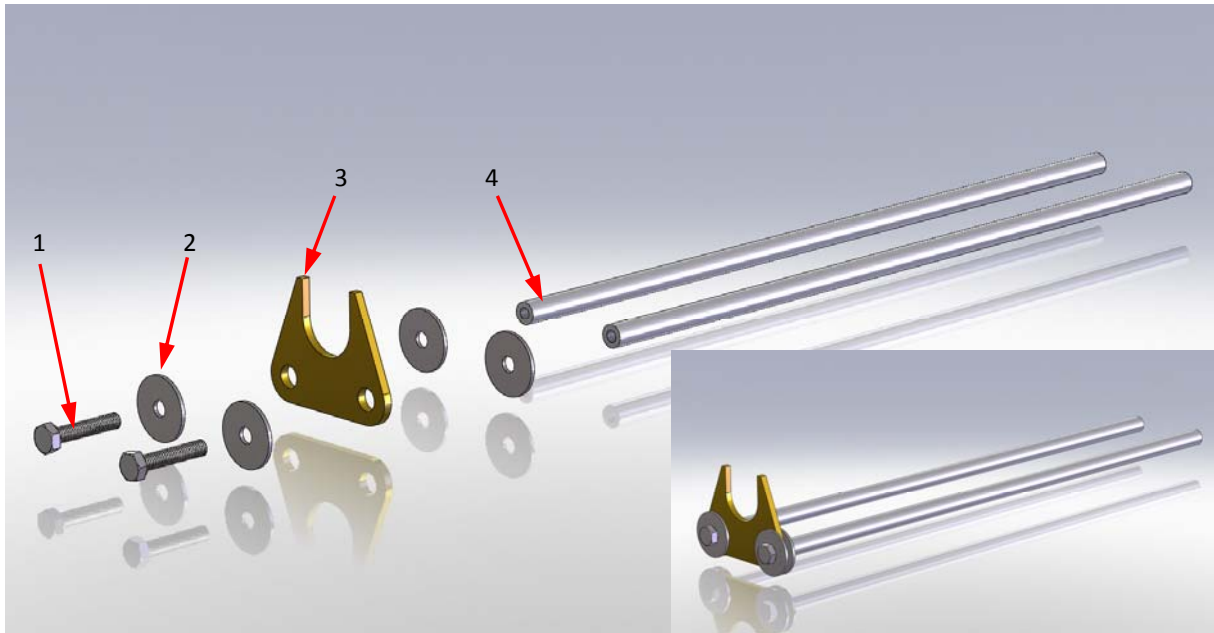

ITEM	No. OFF	PART No.	DESCRIPTION
1	2	Z305-06-030	SCREW
2	4	Z600-06-025	WASHER
3	1	SEE BELOW	FOOT PIECE
4	2	81-111-029	LEG

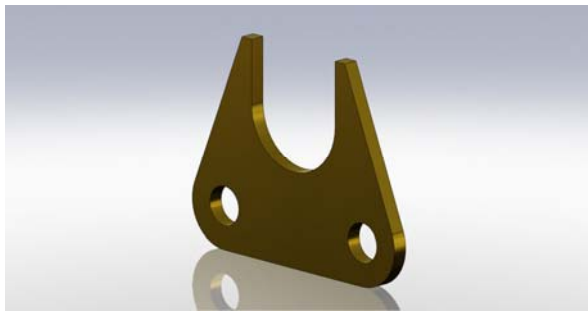

PART No.	DESCRIPTION
89-101-270	12mm FOOT PIECE
89-101-257	16mm FOOT PIECE
89-101-258	19mm FOOT PIECE
89-101-250	22mm FOOT PIECE
89-101-238	25mm FOOT PIECE

PART No.	DESCRIPTION
87-101-012	12mm SHEAR CONNECTOR CHUCK
87-101-016	16mm SHEAR CONNECTOR CHUCK
87-101-019	19mm SHEAR CONNECTOR CHUCK
87-101-022	22mm SHEAR CONNECTOR CHUCK
87-101-025	25mm SHEAR CONNECTOR CHUCK

TOOL	PART No.
METRIC KEY SET	98-100-003



ACCESSORIES - EXTENDED FOOT ASSEMBLY

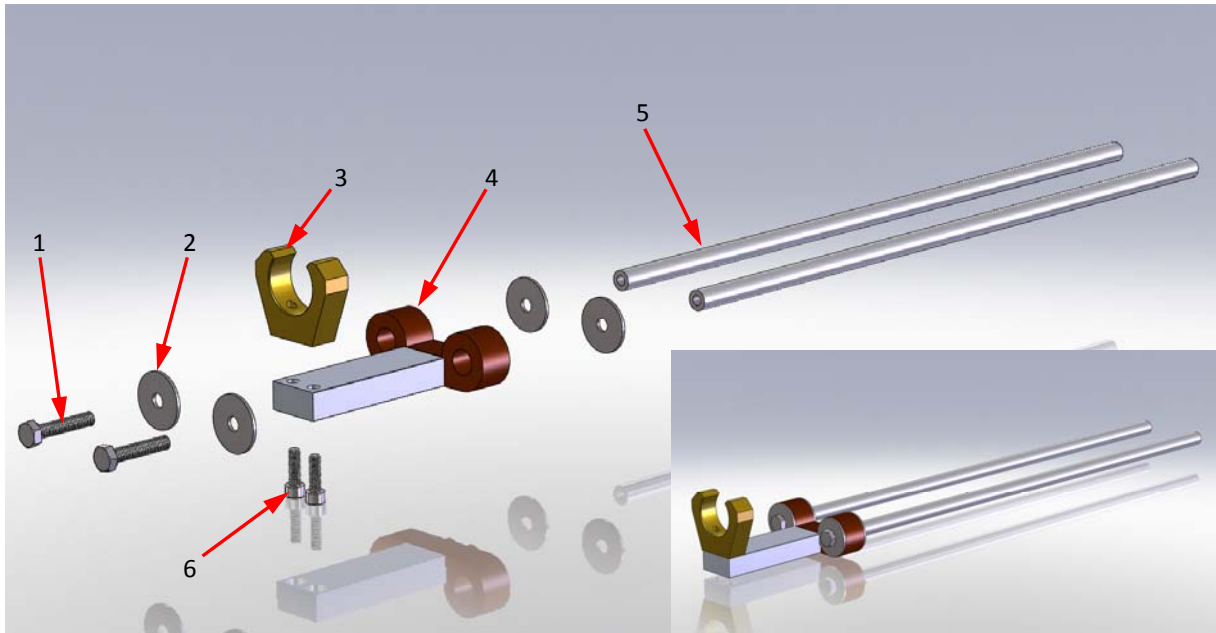

ITEM	No. OFF	PART No.	DESCRIPTION
1	2	Z305-06-030	SCREW
2	4	Z600-06-025	WASHER
3	1	SEE BELOW	"C" PIECE
4	1	SEE BELOW	STEM/BUTTERFLY ASSEMBLY
5	2	81-111-029	LEG
6	2	Z105-05-016	SCREW

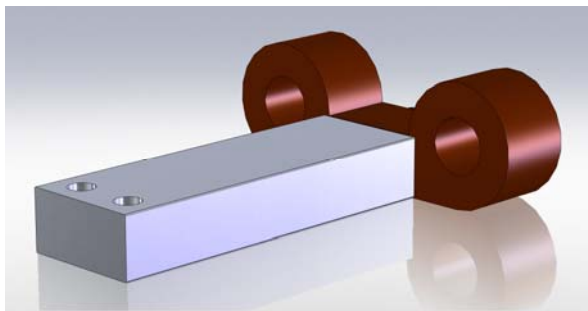

PART No.	DESCRIPTION
87-101-018	STEM/BUTTERFLY ASSEMBLY

PART No.	DESCRIPTION
89-101-123	19mm "C" PIECE FOR EXT. ASSY
89-101-137	22mm "C" PIECE FOR EXT. ASSY
89-101-138	25mm "C" PIECE FOR EXT. ASSY



ACCESSORIES - "TO BEAM" FOOT ASSEMBLY

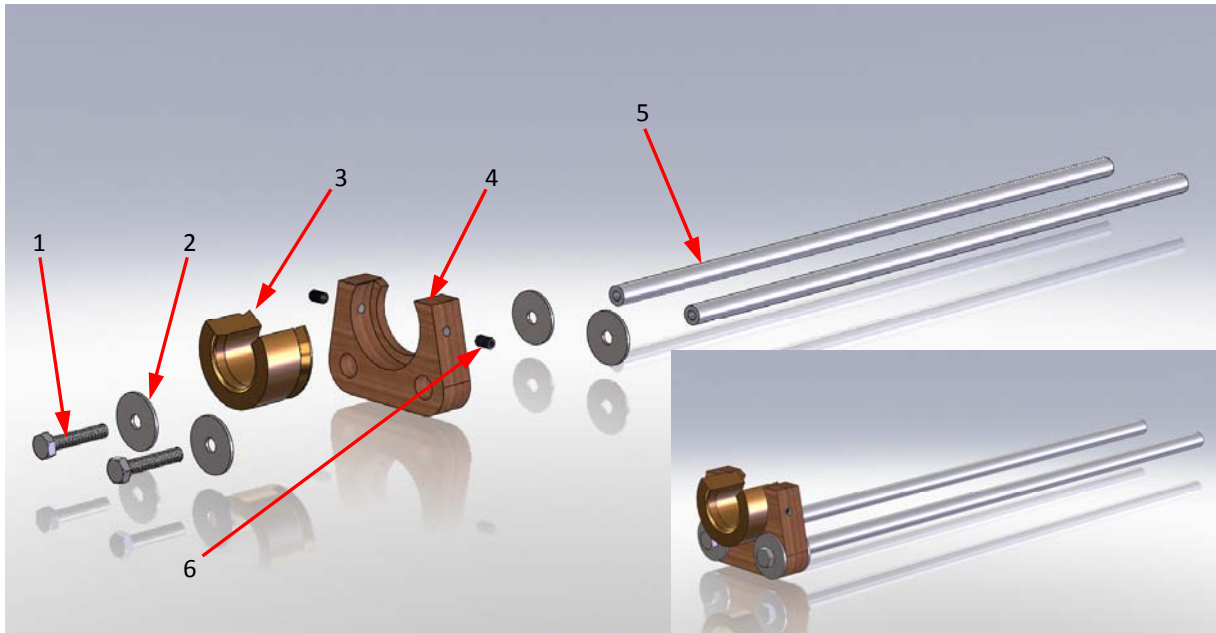

ITEM	No. OFF	PART No.	DESCRIPTION
1	2	Z305-06-030	SCREW
2	4	Z600-06-025	WASHER
3	1	SEE BELOW	"C" PIECE
4	1	89-101-342	FOOT ADAPTOR
5	2	81-111-029	LEG
6	2	Z410-05-010	SET SCREW

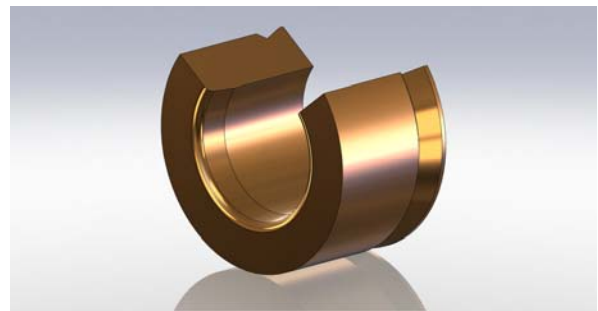

PART No.	DESCRIPTION
87-101-026	19mm TO BEAM FOOT ASSEMBLY
87-101-027	22mm TO BEAM FOOT ASSEMBLY
87-101-028	25mm TO BEAM FOOT ASSEMBLY

PART No.	DESCRIPTION
89-101-343	19mm "C" PIECE
89-101-351	22mm "C" PIECE
89-101-352	25mm "C" PIECE



EC DECLARATION

TAYLOR STUDWELDING SYSTEMS LIMITED

COMMERCIAL ROAD

DEWSBURY

WEST YORKSHIRE

ENGLAND

WF13 2BD

TEL : +44 (0)1924 452123

FAX : +44 (0)1924 430059

EMAIL : sales@taylor-studwelding.com



This is to certify that the machinery listed below is designed and manufactured in conformance with all applicable health and safety regulations.

This statement is invalid if any modifications are carried out on the machinery without the prior written approval of Taylor Studwelding Systems Ltd.

DESCRIPTION OF MACHINE	:	Drawn Arc Studwelding Pistol
TYPE	:	DA6 HI-LIFT
PART NUMBER	:	99-101-029

Applicable EC guidelines and corresponding standards:

- Low voltage guideline 73/23/EEC:

EN60204-1 Safety of machinery - Electrical equipment of machines.

- EMC guidelines 89/336/EEC (electromagnetic compatibility):

EN50081 Electromagnetic compatibility - Generic emission standard

EN50082 Electromagnetic compatibility - Generic immunity standard

EN50199 Electromagnetic compatibility (EMC) Product standard for Arc welding equipment

- Machine guidelines 89/392/EEC

EN60974-1 Arc welding equipment : Electromagnetic compatibility (EMC)

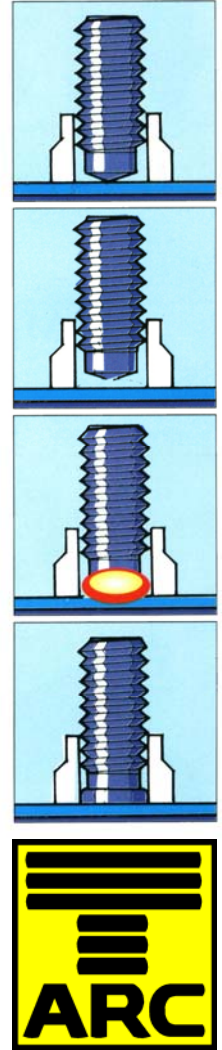

SIGNED

A handwritten signature in black ink, appearing to read 'D Taylor', written over a yellow background.

DAVID TAYLOR
MANAGING DIRECTOR

