

TAYLOR STUDWELDING SYSTEMS LIMITED



OPERATING GUIDE

FOR

AUTO-FEED HANDTOOL

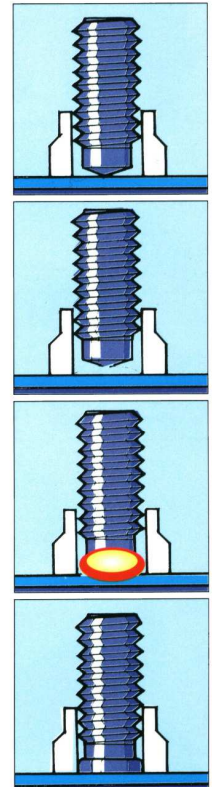
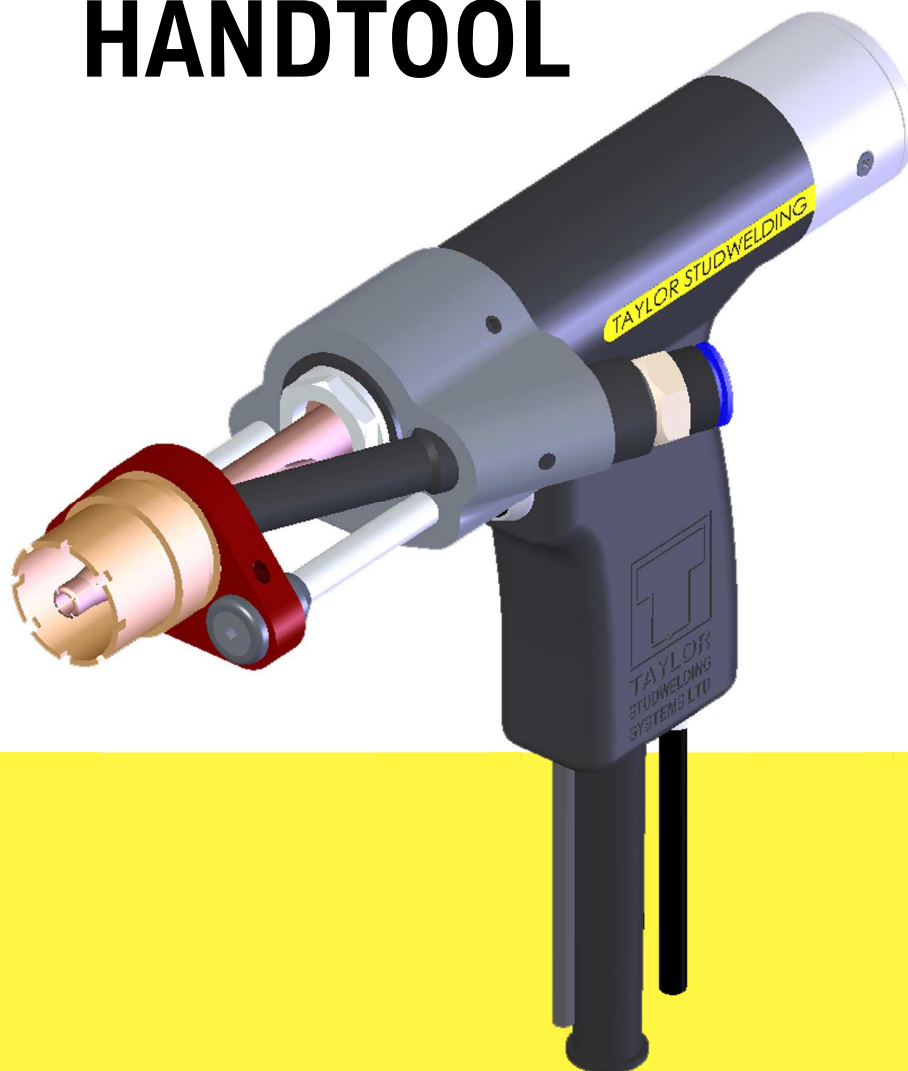

A TAYLORMADE AUTOFEED STUDWELDING SYSTEM FOR CD AND SHORT CYCLE STUDS

INDEX

PAGE	CONTENT
3	General information
5	Introduction
7	Equipment schedule
8	Safety
11	Setting up & welding - Pistol
17	Setting up & welding - Welding
19	Weld quality
21	Trouble shooting
23	Pistol component explosion
35	Accessories
40	EC declaration of conformity

GENERAL INFORMATION



MANUFACTURERS DETAILS

**TAYLOR STUDWELDING SYSTEMS LIMITED
COMMERCIAL ROAD
DEWSBURY
WEST YORKSHIRE
WF13 2BD
ENGLAND**

TELEPHONE	:	+44 (0)1924 452123
FACSIMILE	:	+44 (0)1924 430059
e-mail	:	info@taylor-studwelding.com
TECHNICAL TEL	:	+44 (0)1924 487703
SALES TEL	:	+44 (0)1924 487701

PURPOSE AND CONTENT OF THIS MANUAL

This manual has been written for :

-  **The operator of the welding machine.**
-  **The personnel of the final customer responsible for the installation and operation of the machine.**

This manual contains information on :

-  **Installation and connection**
-  **Operation.**
-  **Technical data.**
-  **Spare parts.**
-  **Accessories.**

GENERAL INFORMATION

FURTHER INFORMATION

Should you require additional technical information, please contact us directly (details on page 3) or our local agent / distributor (details of agents etc. can be obtained from us).

This manual contains important information which is a pre-requisite for safe operation of the equipment. The operating personnel must be able to consult this manual. In the interests of safety, make this manual available to your personnel in good time.

If the equipment is sold / passed on, please hand over this manual to the new owner. Please immediately inform us of the name and address of the new owner, in case we need to contact him regarding the safety of the device.



Please read this manual carefully before installation of the machine.



Please especially observe the safety instructions.

INTRODUCTION

INTRODUCTION

The complete range of Taylor Studwelding Systems Capacitor Discharge and Drawn Arc units are compact, portable Stud Welding equipments. The units are specifically designed to enable a small diameter range of ferrous and non-ferrous weld studs to be welded to light gauge, self-finish or pre-coated materials, and in the case of CD with little or no reverse marking.

The equipment consists of an automatic feed welding pistol, bowl feed and sequence unit and the necessary interconnecting cables and accessories (see page 7 for the equipment schedule).

Two different processes are available: Capacitor Discharge (CD) and Drawn Arc (DA), these are outlined below.

THE PROCESS (CD)

Capacitor Discharge stud welding is a form of welding in which the energy required for the welding process is derived from a bank of charged capacitors. This stored energy is discharged across the gap between the two surfaces to be welded as they are propelled towards each other. The arc produced heats the two surfaces, melting a thin film of metal on each surface and the propelling force closes the gap between the two faces, thus forming a weld.

In contact welding the stud to be welded is forced by spring pressure on to the plate. At this point the arc gap between the two components is maintained by a small pip on the welding face of the stud. On initiation of the high current pulse from the capacitors, this pip vaporises and an arc is drawn between the workpiece and the stud. The heat from this arc melts the base of the stud and the area of the work piece directly beneath the stud, whilst the spring pressure from the pistol accelerates the stud towards the workpiece. Within 3 to 4 milliseconds the stud hits the workpiece and the arc is extinguished. The kinetic energy contained in the moving stud and the remaining spring pressure, forge the molten parts together to form a weld.

INTRODUCTION

THE PROCESS (DA)

The Drawn Arc process is a long established, well proven method of stud welding. The pistol lifts the stud to be welded away from the workpiece, simultaneously striking an arc between the two. This causes both the stud and the workpiece to melt. After the pre-selected weld time has elapsed, the pistol returns the stud to the molten pool on the workpiece, thus forming the weld. The energy required to perform the weld is derived from a transformer - rectifier in the weld control unit.

Infinitely variable weld time allows for short cycle welding, with or without inert gas purging.

EQUIPMENT SCHEDULE

EQUIPMENT - Capacitor Discharge

No Off	Description	Part No
1	CD Auto feed contact hand tool	99-100-180
or	CD Auto feed lift gap hand tool	99-100-181

EQUIPMENT - Drawn Arc

No Off	Description	Part No
1	DA Auto feed contact hand tool	99-101-130

Note: The weld pistol is supplied set up for one stud diameter, see pages 55 to 59 for a full list components for each stud size.

Also a suitable CD or DA weld controller is needed, see the separate documentation for details on how to set these up.

ACCESSORIES

No Off	Description	Part No
1	Jacket Allen key set	98-100-003
1	Collet spanner	98-100-024

SAFETY

PROTECT YOURSELF AND OTHERS !

Read and understand these safety notices.

1. ELECTRICAL

No portion of the outer cover of the welding controller should be removed by anyone other than suitably qualified personnel and never whilst mains power is connected. **ALWAYS** disconnect the mains plug from the socket.



RISK TO LIFE !!!

BE AWARE ! The CD equipment may contain a sealed power supply module which operates on high frequency inverter principles. Due to the potentially fatal voltages in this module we do not recommend tampering with the module. It can be safely removed and replaced via our factory exchange system.

BE AWARE ! Capacitors store electrical energy. Check for residual charge before carrying out any internal maintenance.

DO NOT ! use any fluids to clean electrical components as these may penetrate into the electrical system

Installation must be according to the setting up procedure detailed on pages 11 to 19 of this manual and must be in line with national, regional and local safety codes.

2. FIRE

During welding small particles of very hot metal are expelled. Ensure that no combustible materials can be ignited by these.

SAFETY

3. PERSONNEL SAFETY

Arc rays can burn your eyes and skin and noise can damage your hearing.

Operators and personnel working in close proximity must wear suitable eye, ear and body protection.

Fumes and gases can seriously harm your health. Use the equipment only in a suitably ventilated area. If ventilation is inadequate, then appropriate fume extraction equipment must be used.

Hot metal spatter can cause fire and burns. Appropriate clothing must be worn.

Clothing made from, or soiled with, combustible materials must NOT be worn. Have a fire extinguisher nearby and know how to use it.

Magnetic fields from high currents can affect heart pacemakers or other electronically controlled medical devices. It is imperative that all personnel likely to come into the vicinity of any welding plant are warned of the possible RISK TO LIFE before entering the area.

4. MAINTENANCE

All cables must be inspected regularly to ensure that no danger exists from worn or damaged insulation or from unsound electrical connections. Special note should be made of the cables close to the pistol, where maximum wear occurs.

As well as producing inconsistent welds, worn cables can overheat or spark, giving rise to the risk of fire.

5. TRAINING

Use of the equipment must be limited to authorised personnel only who must be suitably trained and must have read and understood this manual. This manual must be made available to all operators at all times. Further copies of this manual may be purchased from the manufacturer. Measures must be taken to prevent the use of this equipment by unauthorised personnel.

SAFETY

6. INSTALLATION

Ensure that the site chosen for the equipment is able to support the weight of the equipment and that it will not fall or cause a danger in the course of its normal operation. Do not hang connecting cables over sharp edges and do not install connecting cables near heat sources or via traffic routes where people may trip over them or they may be damaged by the passage of vehicles (forklifts etc.).

7. INTERFERENCE

During welding operations, intense magnetic and electrical fields are unavoidably produced and these may interfere with other sensitive electronic equipment.

As previously mentioned, all personnel wearing heart pacemakers or other electronically controlled medical devices must be kept well away from any welding operations.

The welding equipment should be installed at least 5 metres away from any computer equipment to minimise any possible interaction. Note that cables carrying signals between electronic devices are also capable of picking up interference which may modify the way in which those devices function and therefore should be sited outside the 5 metre zone.

Do not place objects which are sensitive to magnetism near the welding area, wristwatches, credit cards, computer disks etc. may all be rendered useless.

The welding equipment, like all other welding equipment, is itself electronically sensitive and its position relative to other radiation emitting equipment (mobile phones, remote controls, motor speed controllers etc.) must be considered.

8. DISPOSAL

The equipment either wholly or any of its component parts may be disposed of as part of general industrial waste or passed to a scrap merchant. Non of the components used in the manufacture are toxic, carcinogenic or harmful to health.

SETTING UP & WELDING

SETTING UP & WELDING

Select the required weld stud on the basis of diameter, length and material. See our separate catalogues: Capacitor Discharge Stock list and Drawn Arc Stock list, which are available from your local sales representative.



SETTING UP & WELDING

SETTING UP THE PISTOL

Setup the pistol for the correct stud size. First remove the foot adaptor by loosening the leg clamp screws under the front end cap.

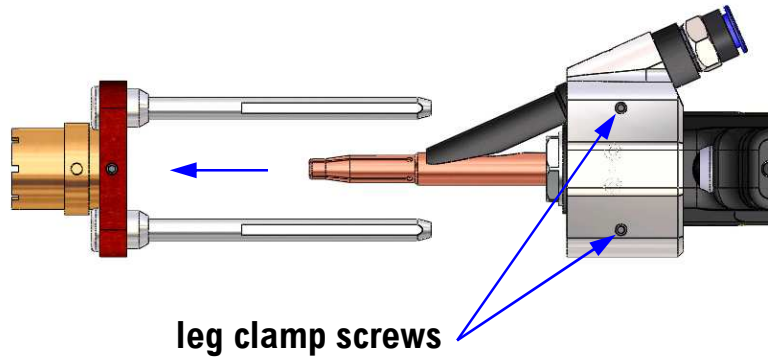

Loosen the feed tube clamp screw and withdraw the feed tube.

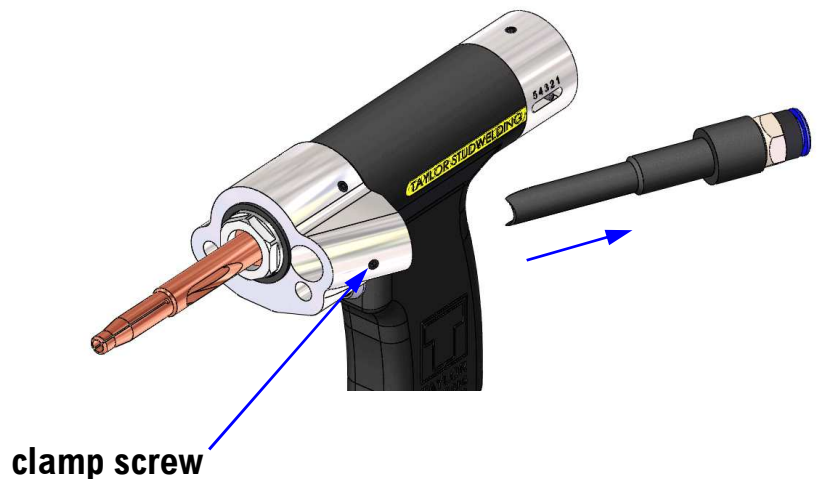

Using the 24mm spanner provided, loosen the collet nut by 1 turn. With the pneumatic shut-off valve turned ON, tap the collet several times with the spanner, this will free the collet from its taper. Turn the pneumatic shut-off valve to OFF and fully unscrew the collet nut. The collet can now be pulled out of the pistol.

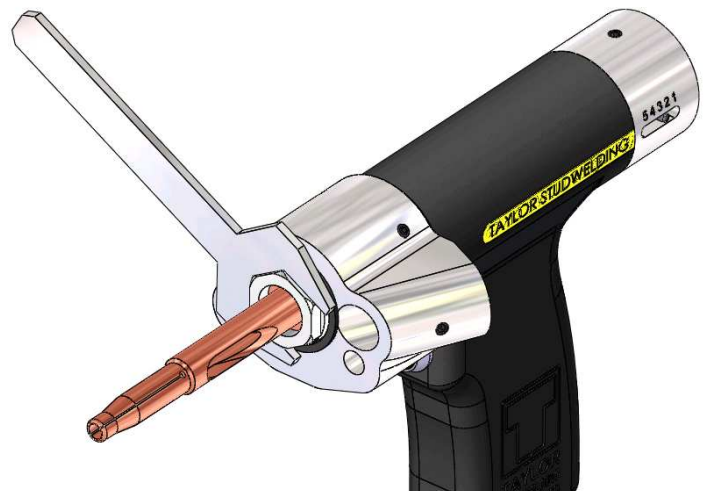

SETTING UP & WELDING

SETTING UP THE PISTOL

Select and insert the correct combination of rod spacers (72-103-028) to give a stud protrusion of 1 to 5mm with the stud length to be used, as shown on page 14.

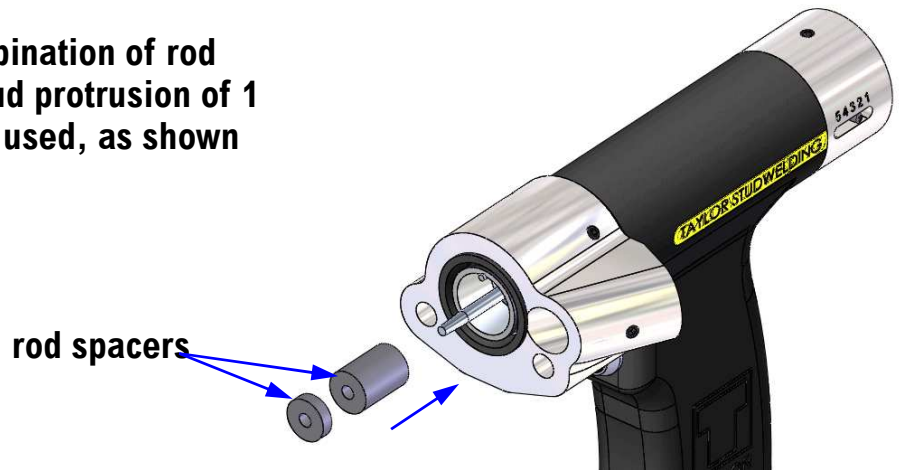

Select the correct collet for the stud to be used (see pages 33 & 34 for a list of collets) and fit it to the pistol as shown with the slot uppermost. Fit the collet nut and tighten with the spanner.

Select the correct feed tube and feed hose gland (see page 35) and fit to the pistol, note the orientation of the feed tube. Tighten the feed tube clamp screw, be careful not to over-tighten this screw.

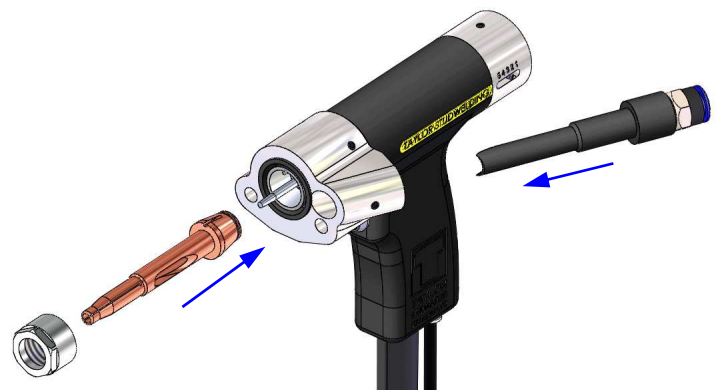

Select the correct size feed hose for the stud to be used (see page 36) and push into the feed hose gland. Make sure that the tube is pushed fully home.

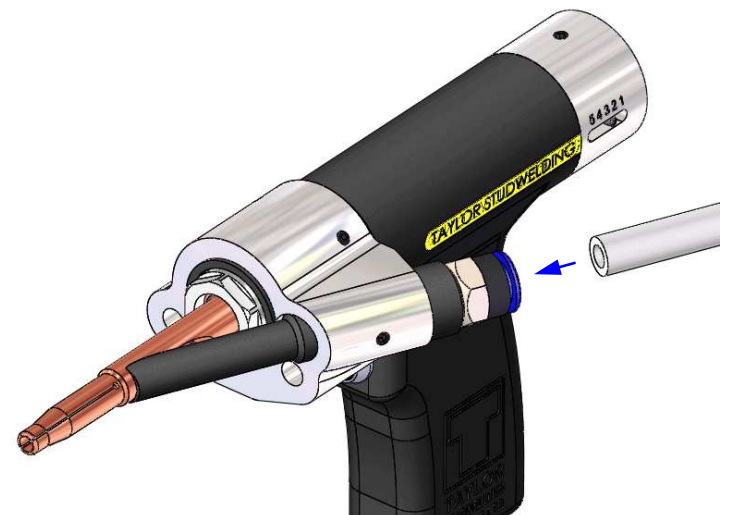

SETTING UP & WELDING

SETTING UP THE PISTOL

Turn the pneumatic shut-off valve to ON and also turn on the mains supply switch. Press the feed stud switch and check the stud protrusion.

1 to 5mm

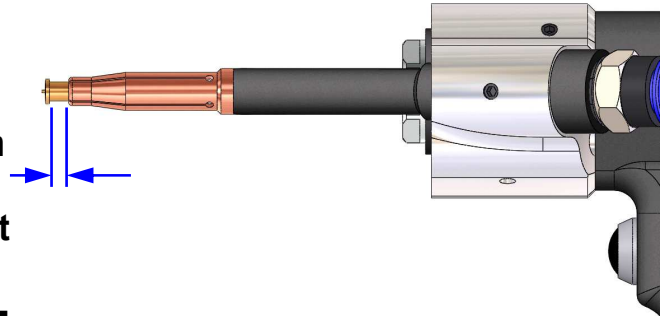

A protrusion of greater than 5mm can be used, but problems may be encountered with the stud cockling over as the pistol is pressed against the workpiece.

Re-fit the foot adaptor and set its position from the end of the nosecone to the back of the stud flange as shown.

Tighten the leg clamp screws.

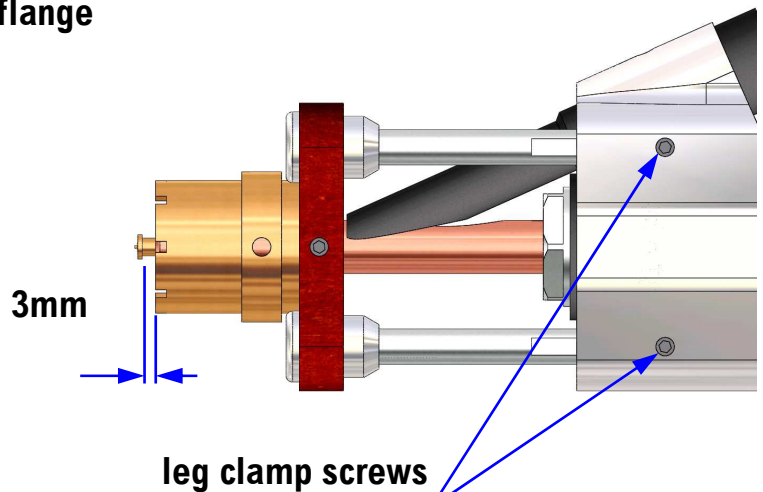

Adjust the position of the nosecone so that it is centred on the stud, by loosening the foot adaptor screws.

This need not be especially accurate, unless the nosecone is to be used to locate the weld position.

If accuracy is important a centring jig is available.

foot adaptor screws

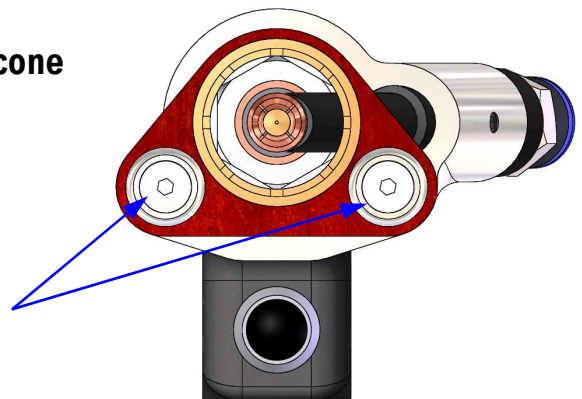

SETTING UP & WELDING

SETTING UP THE PISTOL

STANDARD CONTACT PISTOL

Set the pistol spring preload to the appropriate setting for the welding task to be performed.

Recommended settings are:

Mild steel (CR4), stainless steel (S304) & ZINTEC = 2.5

Aluminium (HE3) = 3.5

(see the manual for the weld controller being used for suggested voltage settings).

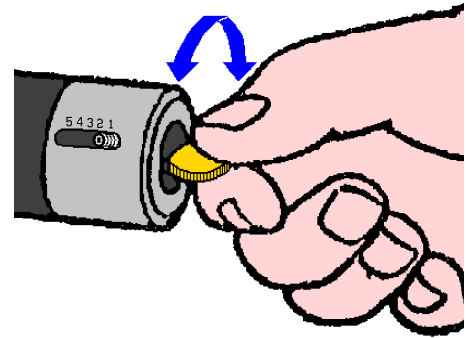

SETTING UP & WELDING

GAP & SHORT CYCLE PISTOL

Set the pistol lift to the appropriate setting for the welding to be performed.

This is achieved by placing the pistol in the welding position, thereby pushing the tip of the weld stud back level with the end of the nosecone. Whilst the pistol is being held firmly in this position, twist the rear end cap of the pistol clockwise until the motion becomes stiff.

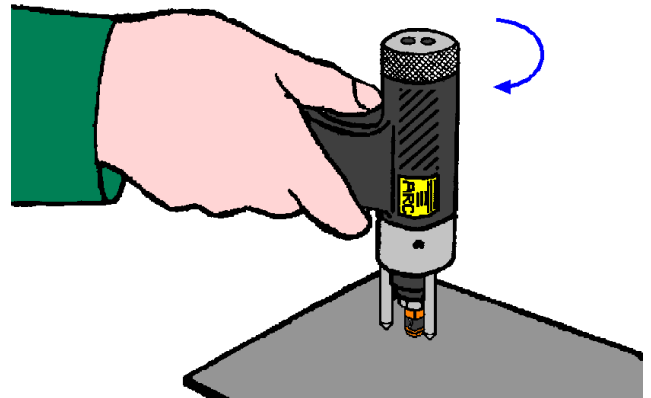

It is at this point that further twisting of the end cap begins to lift the nosecone away from the plate.

The pistol is now at the zero lift position and twisting the rear end cap anti-clockwise by one “click” at a time will increase the lift in steps of 0.25mm (see the manual for the weld controller being used for suggested settings).

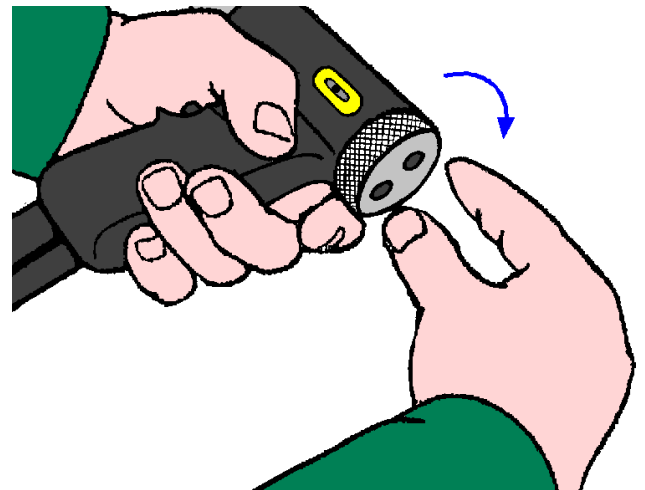

To prevent inadvertent movement of the lift adjustment, the end cap can be locked into place by tightening the grub screw in the end cap.

Do not over-tighten this screw, finger tight is sufficient.

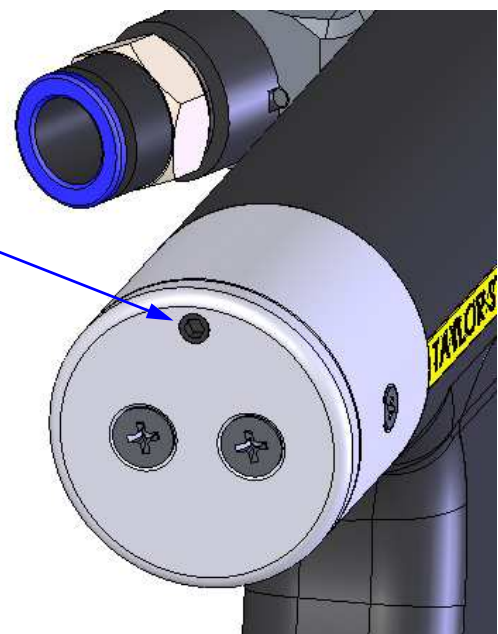

SETTING UP & WELDING

SETTING UP THE WELD CONTROLLER

Set up the capacitor discharge or drawn arc weld controller as shown in the manual appropriate for that piece of equipment.



OR



SETTING UP & WELDING

WELDING

Place the pistol perpendicular to the workpiece with the stud touching down at the location to be welded.

Press down on the pistol until the nosecone is firmly in contact with the workpiece.

Press the trigger.

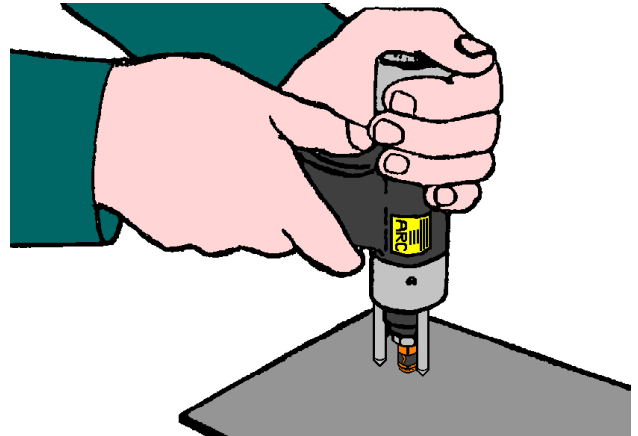

The welding process is as follows:-

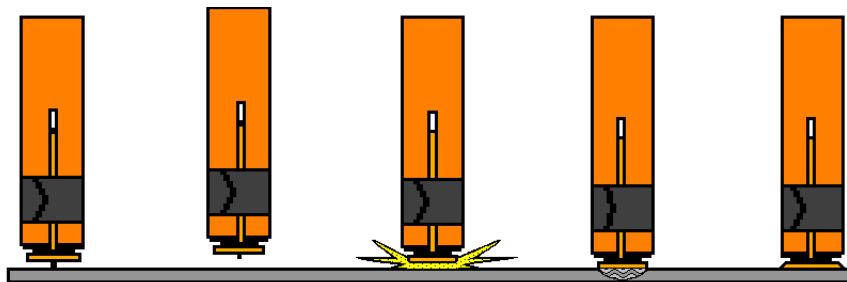

	INITIAL PRESSURE	LIFT & RELEASE	STRIKE ARC	FUSION & IMMERSION	COMPLETED WELD
LIFT GAP PROCESS TIME TAKEN (s)	0.000	0.005	0.001	0.0015	0.002
CONTACT PROCESS TIME TAKEN (s)	0.000	⇒	0.001	0.002	0.003
SHORT CYCLE PROCESS TIME TAKEN (s)	0.000	UP TO 0.5	0.001	0.005	0.02

Always lift the welding pistol vertically from the welded stud. Failure to do this may cause the tines of the collet to splay outwards, which will result in the collet and stud arcing together during subsequent welds.

It is important to pull of the welded stud straightaway as the next stud is automatically fed to the pistol at the end of the weld cycle.

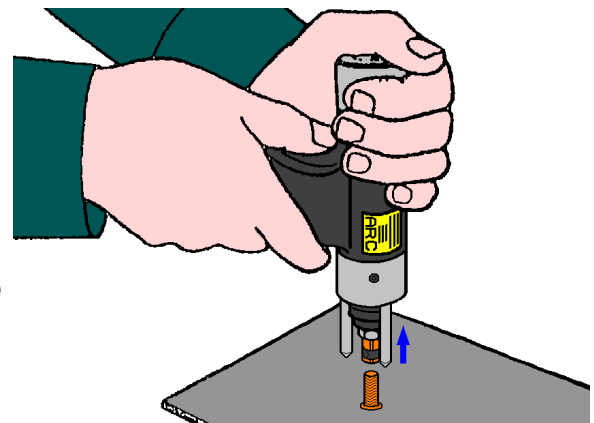

WELD QUALITY

VISUAL ASSESSMENT OF WELD QUALITY

A cold stud weld is noticeable by undercutting of the flange and lack of / minimal formation of spatter. A cold weld is usually caused by too little energy and / or too fast a plunge speed.

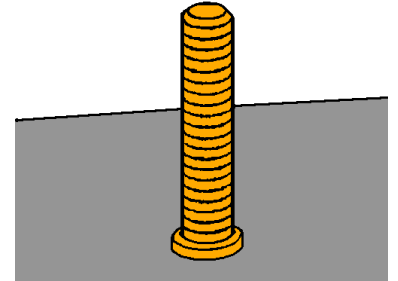

A hot stud weld is noticeable by excessive spatter formation and partial melting of the flange. A hot weld is usually by too much energy and / or too slow a plunge speed.

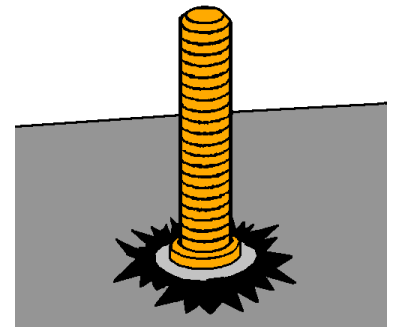

A one sided stud weld (arc blow) is usually caused by incorrect earthing of the work piece. This may be corrected by placing the welding earths opposite each other across the area where the weld is to occur.

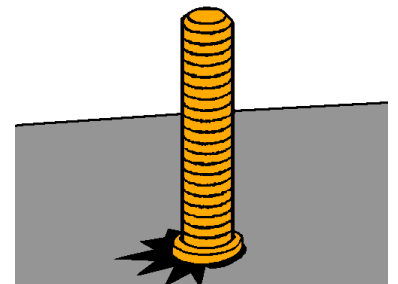

Finished studs may be subjected to a bending test to ascertain the strength of the weld. This may be achieved by placing a bending bar assembly, fitted with the correct nozzle, over the stud and bending the stud through 30° and then back to the vertical. This test follows the specification of BS EN ISO 14555:2006.

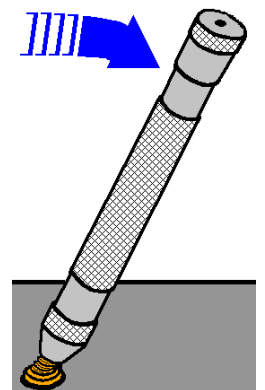

A simpler test may be achieved by bending the stud over 30° using a hide mallet.

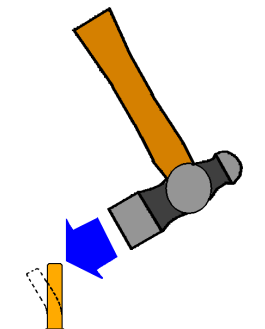

WELD QUALITY

Visual examination of weld quality can, even with limited experience, provide a useful quality assessment. In such a check the presence of a small even witness of weld material around the base of the stud flange after welding should be ensured. Poor welds are indicated by excess metal on one side of the welded flange and / or the presence of an undercut or non-fused area between the stud flange and the parent sheet or plate. Incorrect settings, adverse magnetic effects etc. such as those at edge welding positions or with unbalanced earths and studs welded to the work piece at an angle, the controller and pistol should be examined with a view to correcting such defects.

MECHANICAL TESTS :

① BENDING.

The most easily applied method of testing the quality of welded fasteners considered here, involves the use of a bending bar. This bending bar (available from your supplier, see the accessories section of this manual) fitted with the correct size of nozzle for the stud to be tested is used to bend over the stud in accordance with standard BS EN ISO 14555:2006 .

② TORSION.

A torsion test provides useful information for threaded fasteners. This involves tightening a nut on the stud against a spacer, suitably relieved to cater for the flange and weld spatter. For quantitative assessments a suitably calibrated torque wrench may be used, but at its simplest, a spanner will suffice.

In the above tests the performance of the welded joint should be considered in relation to the thickness of the material to which the stud is welded. On thicker materials, a full strength weld is denoted by deformation or failure of the stud shank. On lighter gauge material, severe "dimpling" or "dishing" at the reverse to the weld side normally indicates sufficient strength, whilst in most cases, the tearing of a slug of material from the parent sheet will occur.

TROUBLE SHOOTING

Fault / Error	Cause	Remedy
Sudden decline in weld quality	Worn welding contacts	Check the contacts of the collet & earth clamps. Replace worn out parts
	Welding energy too high or too low	Too much spatter around the weld area: energy too high - decrease the weld voltage
		No spatter around the weld area: energy too low - increase the weld voltage
	Burnt welding cable plug and sockets. Welding cable damaged	Check the weld cables and replace as necessary
	Plunge speed of the stud too fast or too slow	Check the spring or lift settings in the pistol
	Dimensions of the stud tip outside of tolerance	Check the dimensions of the stud tip. The size and tolerance must be to EN ISO 13918
	Wrong stud material	Check the material of the stud, it must be suitable for welding
	Wrong workpiece material	Check the material of the sheet, it must be suitable for welding
Workpiece surface contaminated	Check the surface of the sheet, it must be clean & free from oil or grease	

TROUBLE SHOOTING

Fault / Error	Cause	Remedy
Studs show material ejected to one side only	Arc blow effect. Earthing contacts not applied evenly	Apply earthing contacts symmetrically to the weld position
Burn marks on stud	Collet contact worn	Replace the collet
No stud in the collet	Stud blockage in the stud feeder	Check the vibrator bowl and stud feeder
	Feed tube	Check that the feed tube is fully inserted into the pistol. If the feed hose is kinked, replace it
	Stud has not reached the collet	Check all the points through which the stud is guided, from the stud feeder down to the collet. Check the air pressure and air flow
	Several studs in the feed tube	Stud arriving at the pistol after the pushrod has returned. Increase the stud blow air flow, or increase the stud feed time
	Worn out collet	Replace the collet

PISTOL COMPONENT EXPLOSION

MAIN BODY

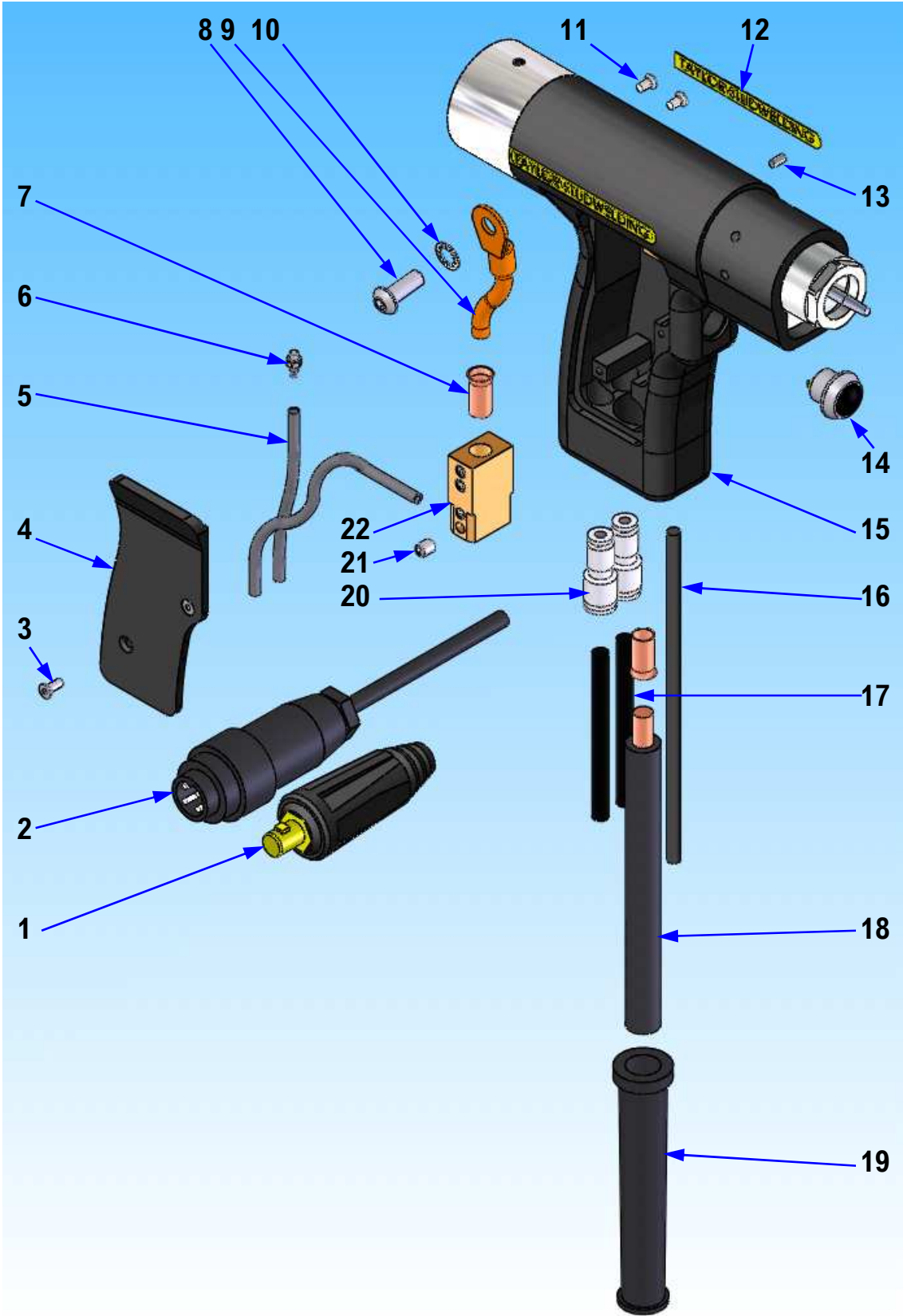

PISTOL COMPONENT EXPLOSION

ITEM No	QTY	DESCRIPTION	PART No
1	1	CABLE END WELD PLUG	81-101-051
2	1	4 PIN CONTROL PLUG	71-101-030
3	2	SKT CSK SCREW M3 x 8 LONG	Z120-03-008
4	1	HANDLE COVER	72-103-019
5	0.2m	4 OD, 2.5 ID PNEUMATIC TUBING	71-200-160
6	1	M3 PNEUMATIC BARB FITTING	71-200-088
7	2	COPPER FERRULE	71-101-042
8	1	SKT BUTTON HD SCREW M6 x 16 LG	Z115-06-016
9	1	WELD BRAID	72-103-038
10	1	M6 SHAKE PROOF WASHER	Z625-06-000
11 *	4	POZIDRIVE CSK SCREW M3 x 5 LG	Z205-03-005
12	2	PISTOL DECAL (PAIR)	72-103-020
13	2	BUSH LOCATION PIN (DIA 3 x 6 LG)	75-101-705
14	1	PUSH BUTTON SWITCH	71-104-019
15	1	PISTOL BODY	72-103-017
16	3.5m	CONTROL CABLE	71-300-014
17	7m	6 OD, 4 ID PNEUMATIC TUBING	71-200-159
18	3m	25mm ² WELD CABLE	71-300-002
19	1	WELD CABLE SUPPORT SLEEVE	71-101-034
20	2	DIA 4 TO DIA 6 PNEUMATIC FITTING	71-200-208
21	4	FLAT POINT SET SCREW M5 x 8 LG	Z400-05-008
22	1	BRAID RESTRAINING BLOCK	72-103-027
23	1	NYLON CABLE SLEEVE (NOT SHOWN)	72-103-049

* NOTE: FOR SHORT CYCLE FIT 2 OFF ITEM 11 TO REAR HOLES ONLY

PISTOL COMPONENT EXPLOSION

WELD SHAFT

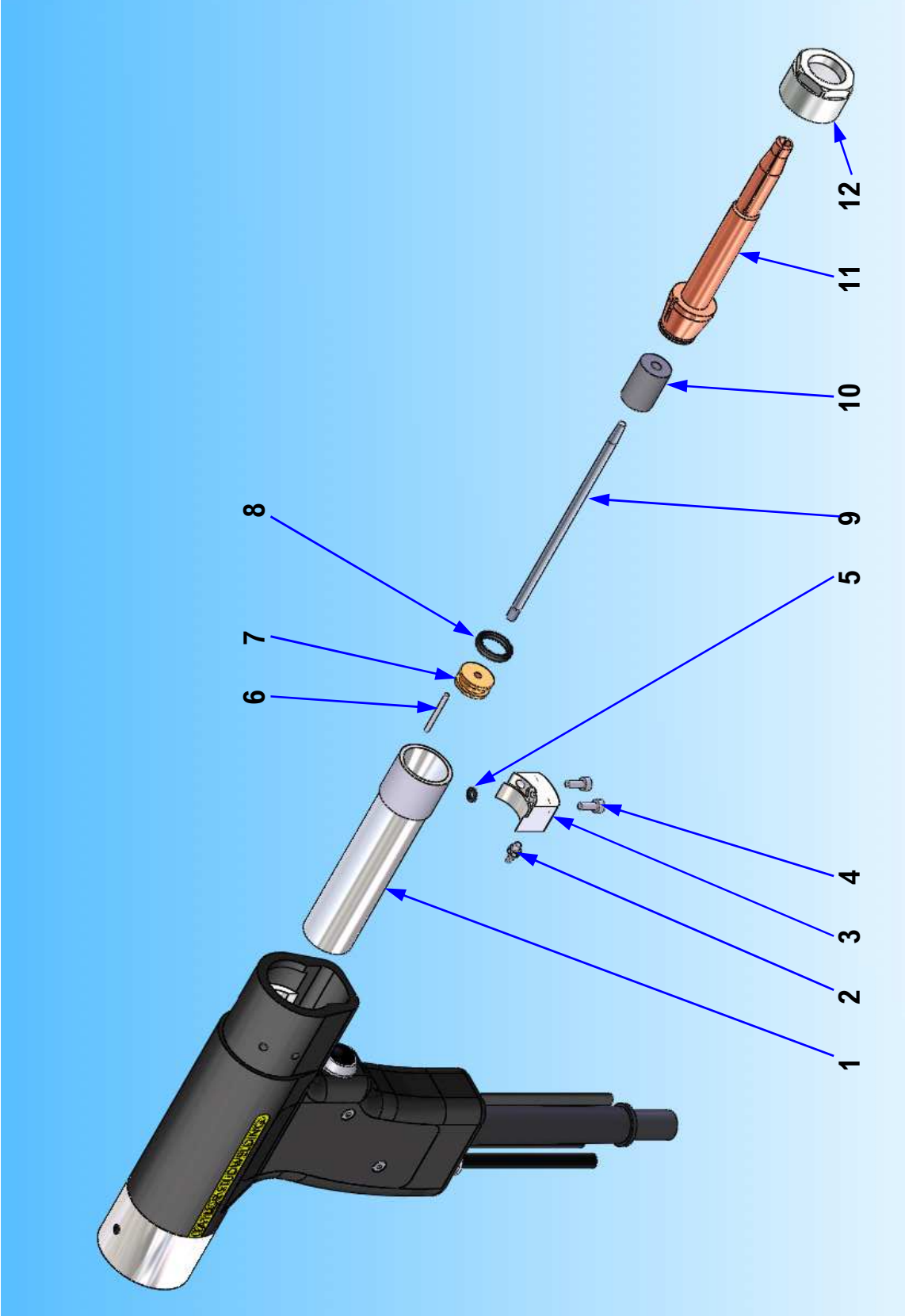

PISTOL COMPONENT EXPLOSION

ITEM No	QTY	DESCRIPTION	PART No
1	1	WELD SHAFT	72-103-001
2	1	M3 PNEUMATIC BARB FITTING	71-200-088
3	1	PNEUMATIC BLOCK	72-103-011
4	2	SKT CAP HD SCREW M3 x 10 LONG	Z105-03-010
5	1	O RING	0031-16
6	1	ANTI-ROTATION PIN	72-103-024
7	1	PISTON	72-103-006
8	1	O RING	0116-24
9	1	PUSH ROD	72-103-005
10	1	ROD SPACER (SET OF 6)	72-103-028
11	1	M3 TO M8 AUTO COLLET ASSEMBLY	SEE PAGES 32 TO 34
12	1	COLLET NUT	72-103-003

Note:

For studs 35mm and longer substitute 72-103-176 for item 9

PISTOL COMPONENT EXPLOSION

FRONT END CAP

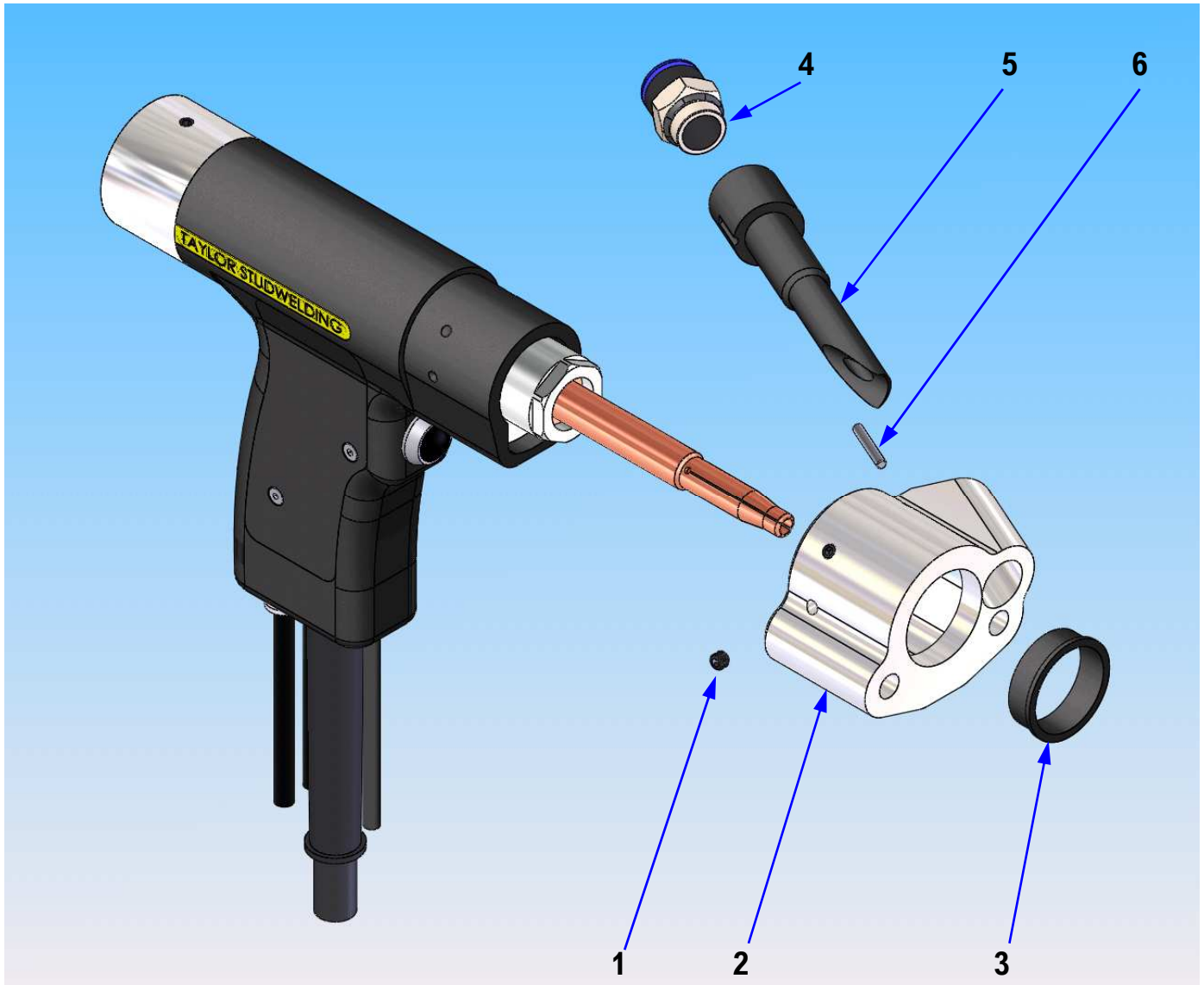

ITEM No	QTY	DESCRIPTION	PART No
1	4	FLAT POINT SET SCREW M5 x 4 LG	Z400-05-004
2	1	FRONT END CAP	72-103-023
3	1	INSULATION SEAL	72-103-025
4	1	FEED TUBE GLAND M3 TO M8	SEE PAGE 37
5	1	FEED TUBE M3 TO M8	SEE PAGE 37
6	1	ALIGNMENT PIN	72-103-037

PISTOL COMPONENT EXPLOSION

LEG ASSEMBLY

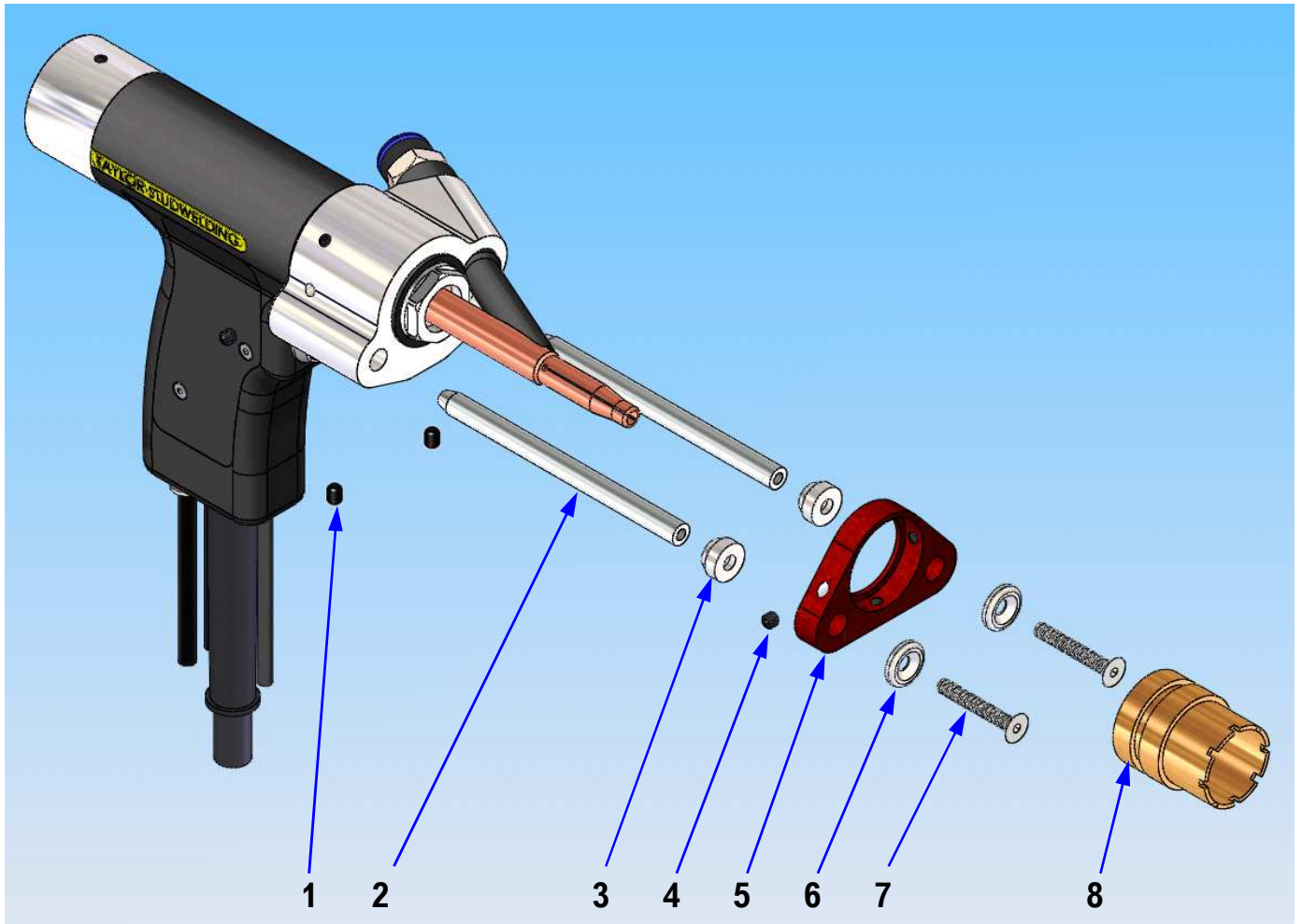

ITEM No	QTY	DESCRIPTION	PART No
1	2	GRUB SCREW M5 x 6 LG	Z400-05-006
2	2	ADJUSTABLE LEG	72-103-034
3	2	FOOT WASHER (REAR)	81-101-001
4	3	FLAT POINT SET SCREW M5 x 4 LG	Z400-05-004
5	1	FOOT ADAPTOR	72-103-026
6	2	FOOT WASHER (FRONT)	81-101-003
7	2	SKT CSK SCREW M5 x 35 LONG	Z125-05-035
8	1	30mm NOSE CONE	89-101-252

PISTOL COMPONENT EXPLOSION

REAR

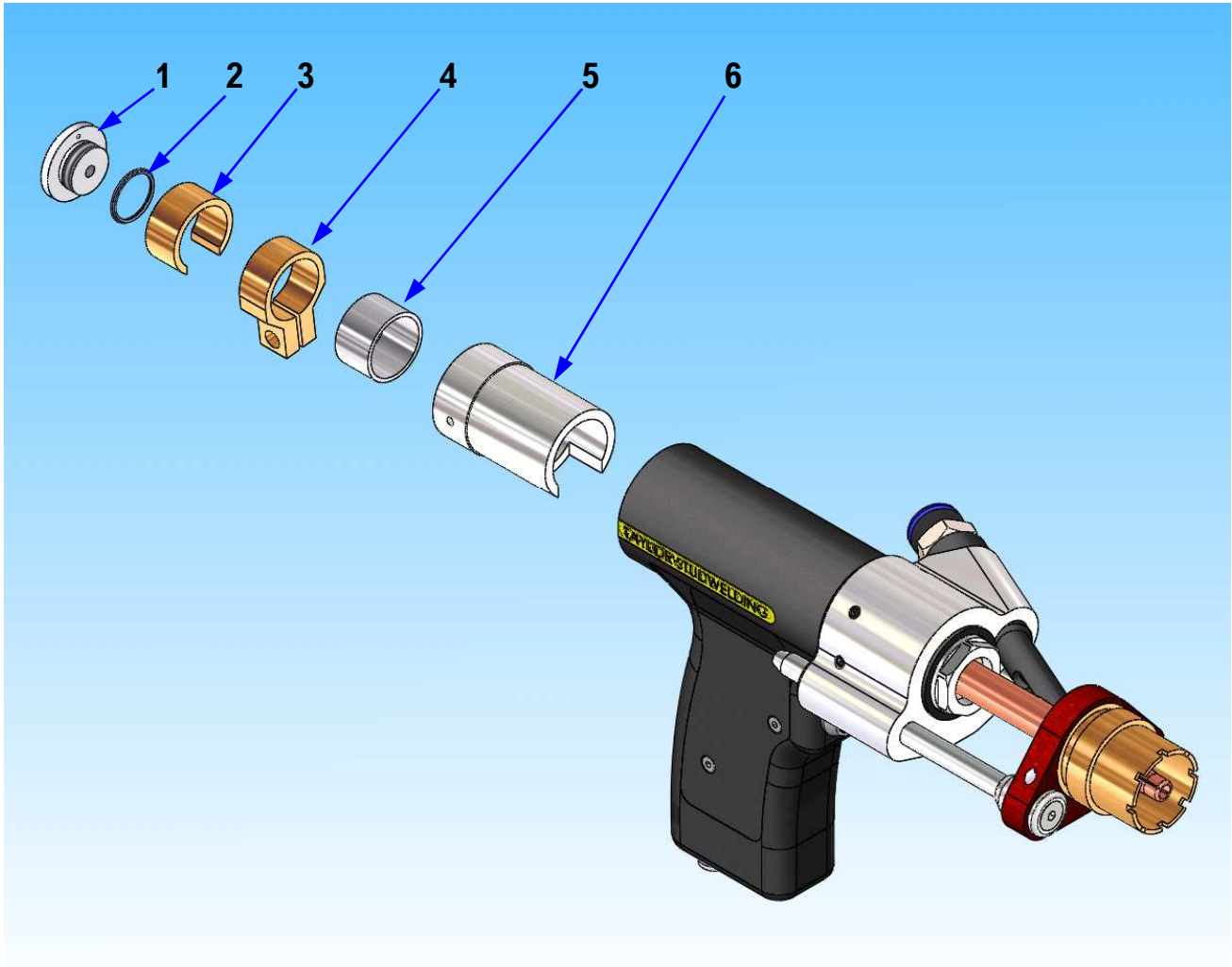

ITEM No	QTY	DESCRIPTION	PART No
1	1	CYLINDER END CAP	72-103-007
2	1	O RING	0161-16
3	1	SHAFT SPACER	72-103-012
4	1	CABLE CONNECTION BLOCK	72-103-010
5	2	LINEAR BEARING	72-103-050
6	1	BEARING SLEEVE	72-103-009

PISTOL COMPONENT EXPLOSION

CONTACT PARTS (99-100-180)

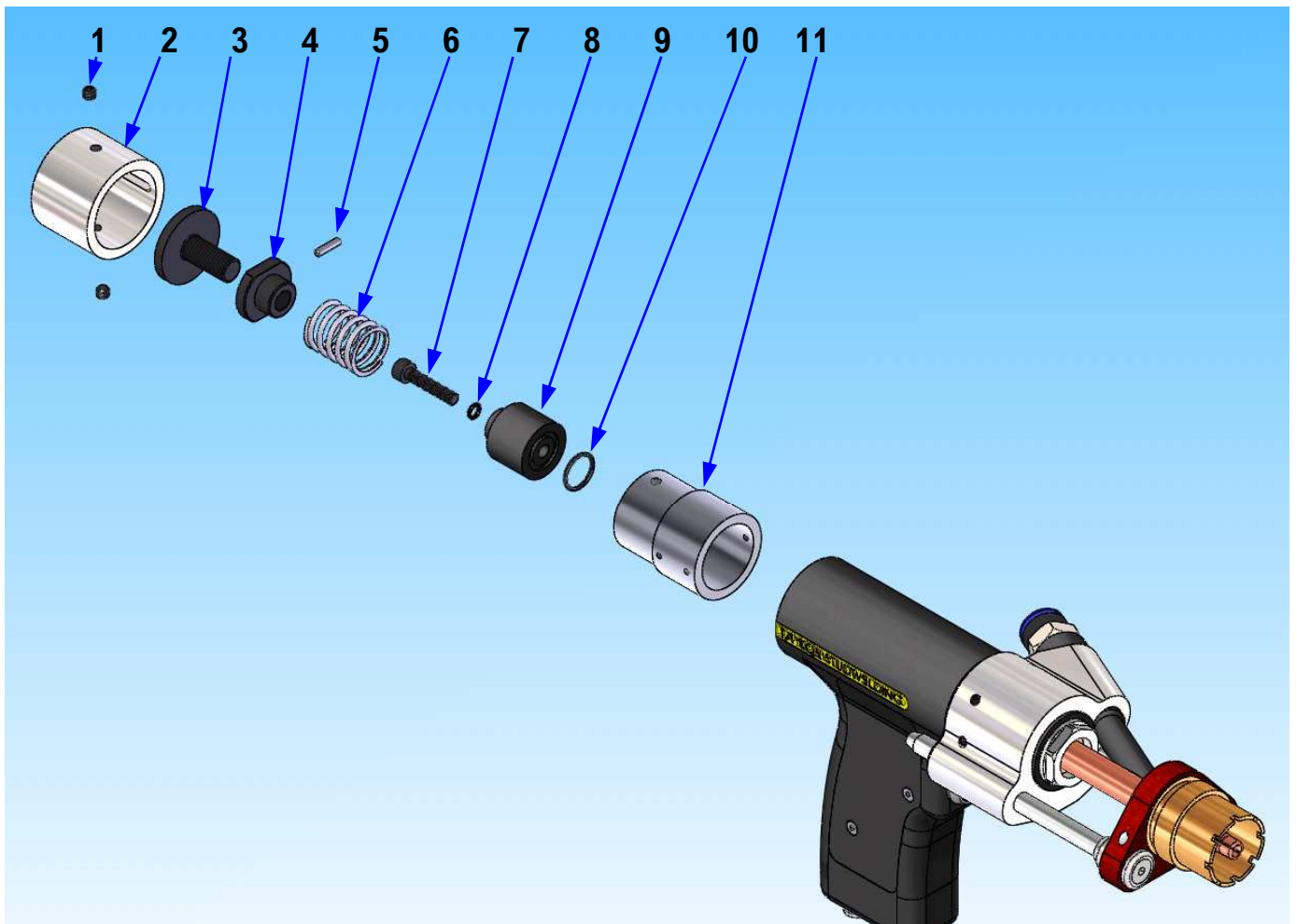

ITEM No	QTY	DESCRIPTION	PART No
1	2	SKT FLAT POINT SET SCREW M5 x 4 LG	Z400-05-004
2	1	REAR END CAP	72-103-030
3	1	PRE LOAD ADJUSTER	71-101-017
4	1	SPRING DEPRESSER	71-101-016
5	1	SKT FLAT POINT SET SCREW M3 x 12 LG	Z400-03-012
6	1	MAIN SPRING	71-101-014
7	1	SKT CAP HD SCREW M5 x 25 LONG	Z100-05-025
8	1	O RING	0041-16
9	1	SPRING SEAT	72-103-029
10	1	O RING	0131-16
11	1	END CAP SLEEVE	72-103-031

PISTOL COMPONENT EXPLOSION

LIFT GAP (99-100-181) & SHORT CYCLE PARTS (99-101-310)

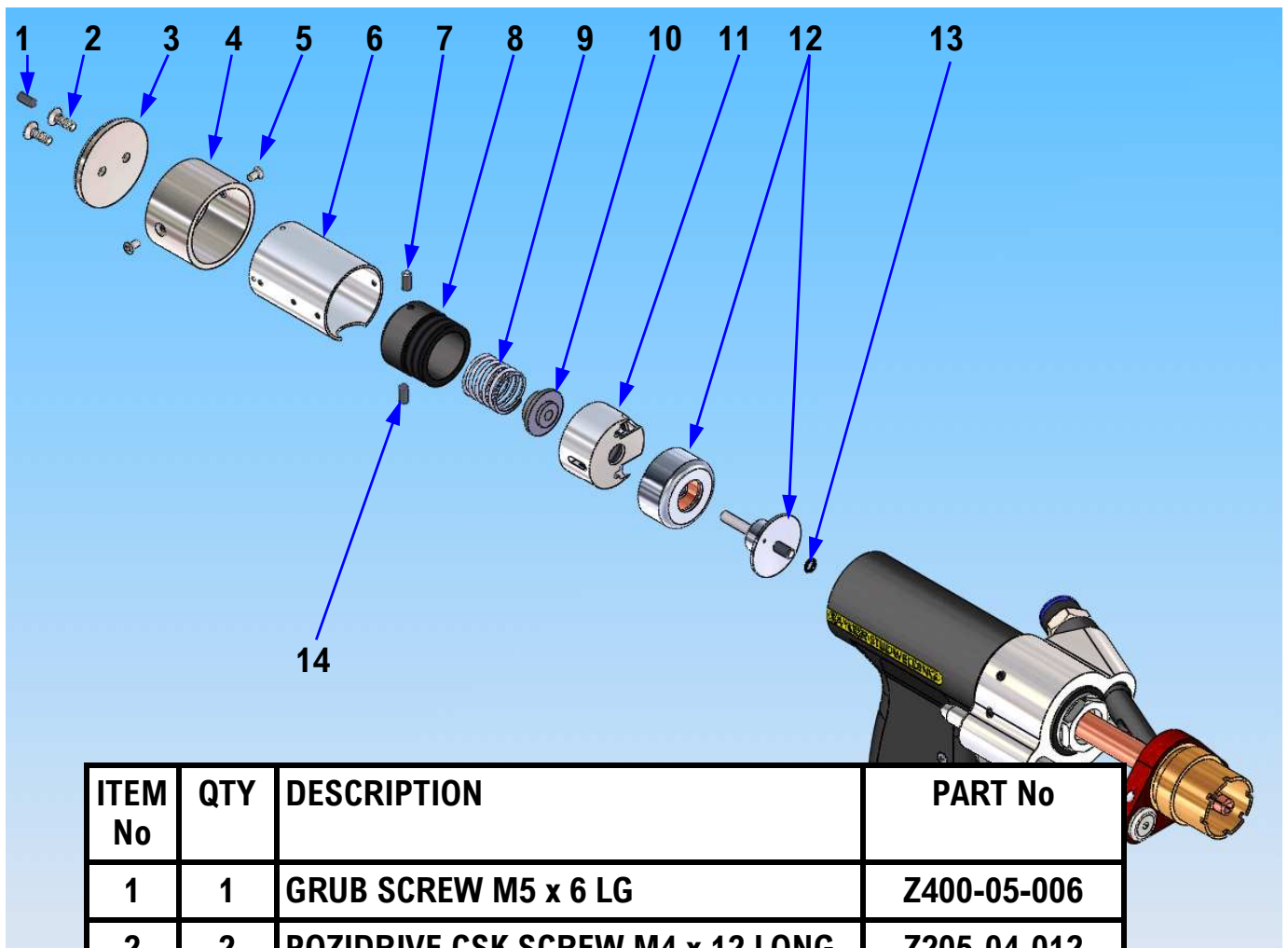

ITEM No	QTY	DESCRIPTION	PART No
1	1	GRUB SCREW M5 x 6 LG	Z400-05-006
2	2	POZIDRIVE CSK SCREW M4 x 12 LONG	Z205-04-012
3	1	END CAP	72-103-015
4	1	REAR SLEEVE	72-103-016
5	2	POZIDRIVE CSK SCREW M3 x 5 LONG	Z205-03-005
6	1	COIL SLEEVE	72-103-036
7	1	LIFT DETENT	72-103-089
8	1	LIFT ADJUSTER	72-103-014
9	1	RETURN SPRING	71-102-009
10	1	SPRING SEAT	72-103-008
11	1	SOLENOID HOUSING	72-103-013
12	1	SOLENOID COIL	72-103-042
13	1	O RING	0041-16
14	1	GRUB SCREW M8 x 10 LG	Z400-08-010

PISTOL COMPONENT EXPLOSION

ONE PIECE COLLET - OLD TYPE

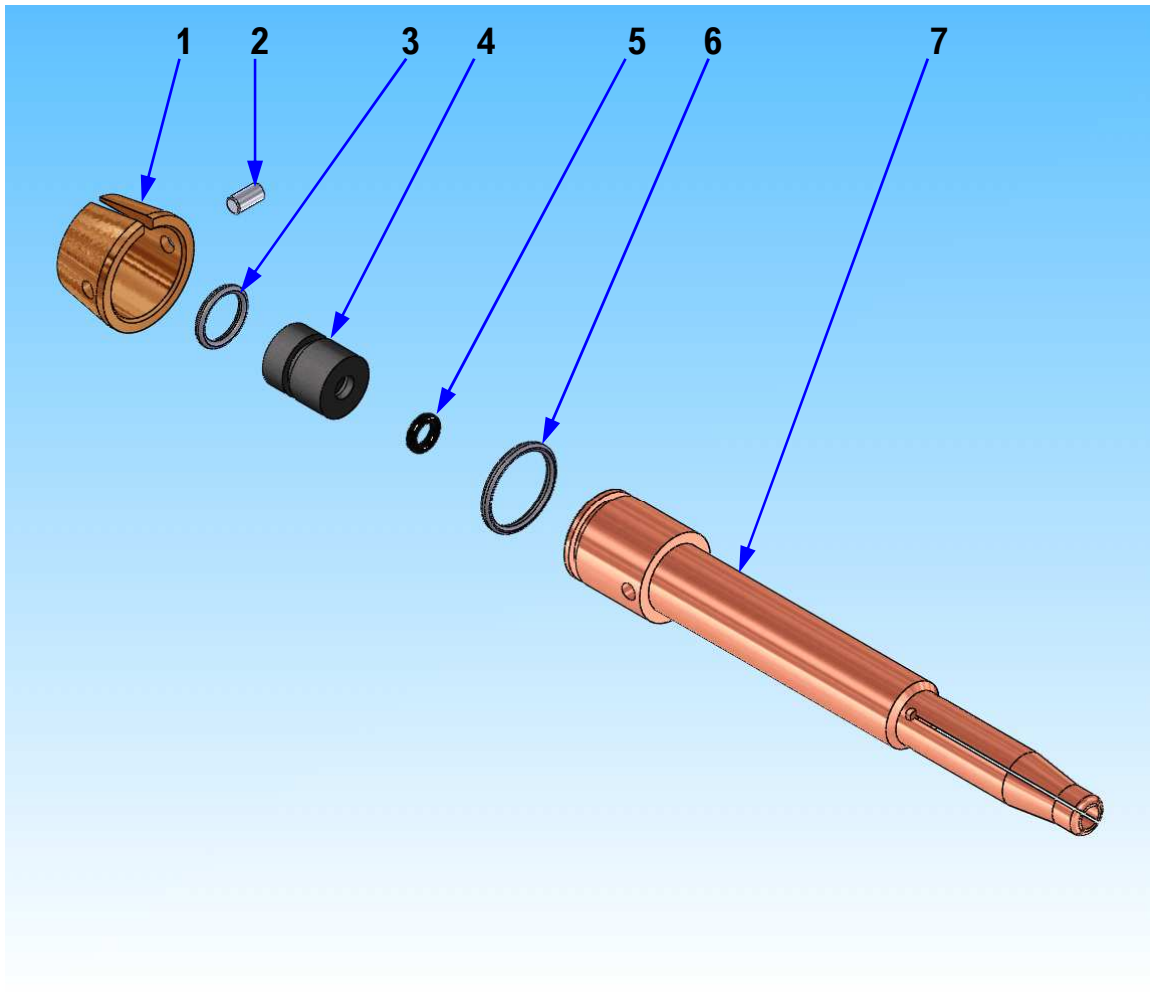

ITEM No	QTY	DESCRIPTION	PART No
1	1	LOCKING SLEEVE	72-103-002
2	1	LOCATION PIN	75-101-705
3	1	O RING	0081-16
4	1	COLLET SEAL	72-103-004
5	1	O RING	0031-16
6	1	O RING	0131-16
7	1	ONE PIECE COLLET M3 TO M8	SEE PAGE 35

There are 2 different types of collet. The older type has a separate locking sleeve, whereas the new type is all one piece.

The older type is being phased out, but there will be some overlap as stock is used up.

PISTOL COMPONENT EXPLOSION

ONE PIECE COLLET - NEW TYPE

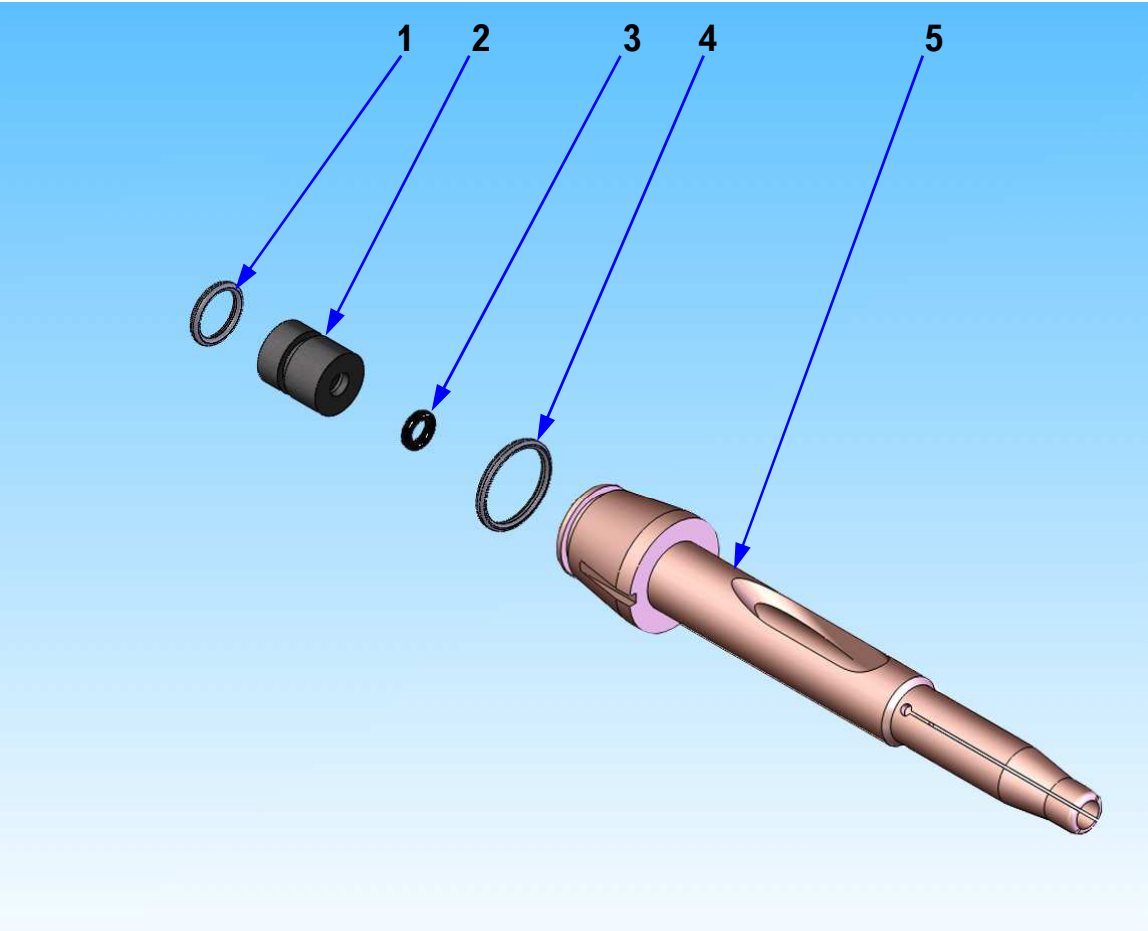

ITEM No	QTY	DESCRIPTION	PART No
1	1	O RING	0081-16
2	1	COLLET SEAL	72-103-004
3	1	O RING	0031-16
4	1	O RING	0131-16
5	1	ONE PIECE COLLET M3 TO M8	SEE PAGE 35

There are 2 different types of collet. The older type has a separate locking sleeve, whereas the new type is all one piece.

The older type is being phased out, but there will be some overlap as stock is used up.

PISTOL COMPONENT EXPLOSION

2 PART COLLET

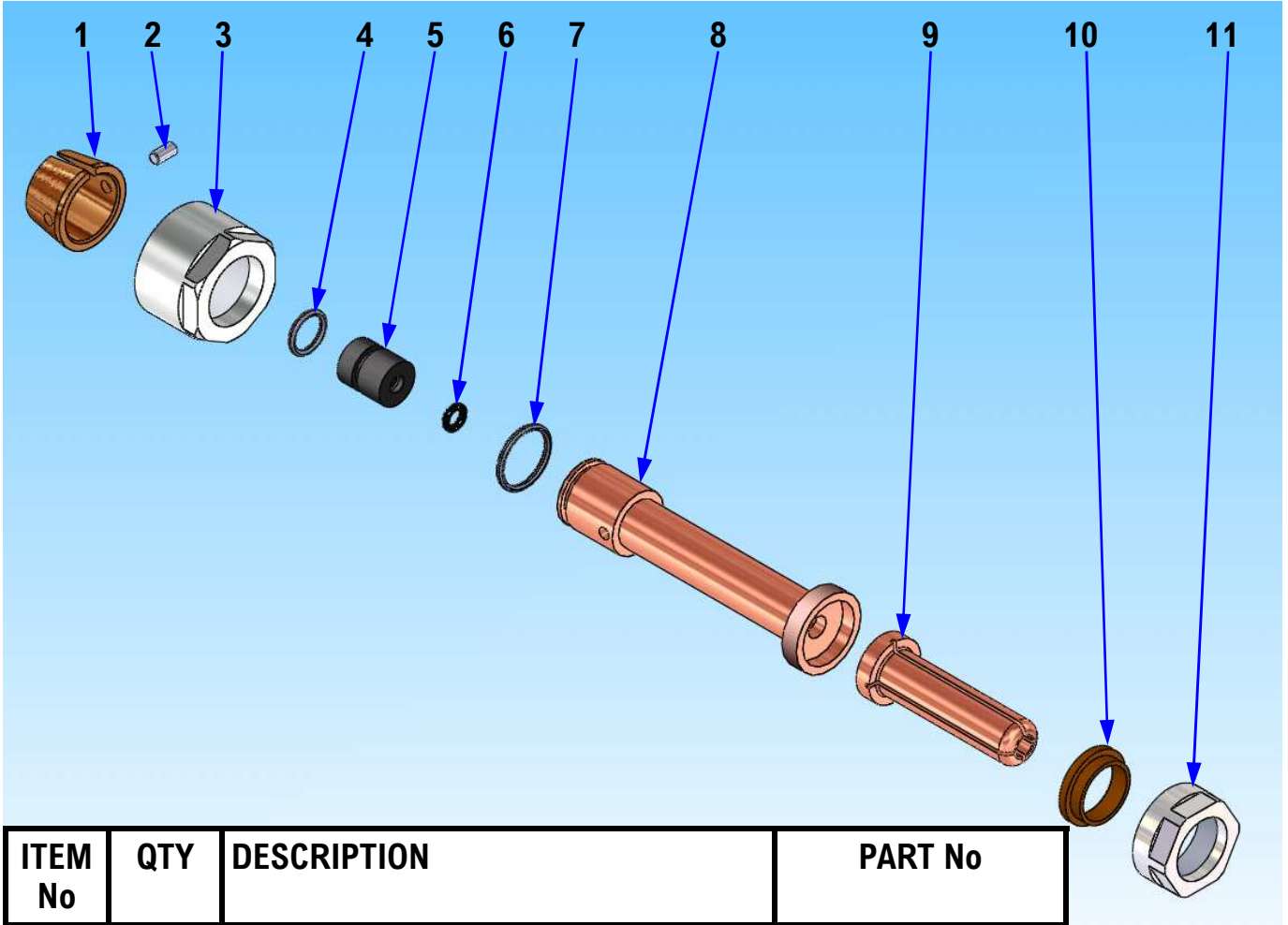

ITEM No	QTY	DESCRIPTION	PART No
1	1	TAPERED OLIVE - COLLET CLAMP	72-103-002
2	1	LOCATION PIN	75-101-705
3	1	COLLET NUT	72-103-003
4	1	O RING	0081-16
5	1	COLLET SEAL	72-103-004
6	1	O RING	0031-16
7	1	O RING	0131-16
8	1	TRANSFER TUBE M3 TO M8	SEE PAGE 36
9	1	COLLET M3 TO M8	SEE PAGE 36
10	1	NUT INSULATOR	72-103-033
11	1	COLLET NUT	72-103-032

ACCESSORIES

COLLET - ONE PIECE

For studs 6 to 16mm long

M3	79-103-113
M4	79-103-114
M5	79-103-115
M6	79-103-116
M8	79-103-118

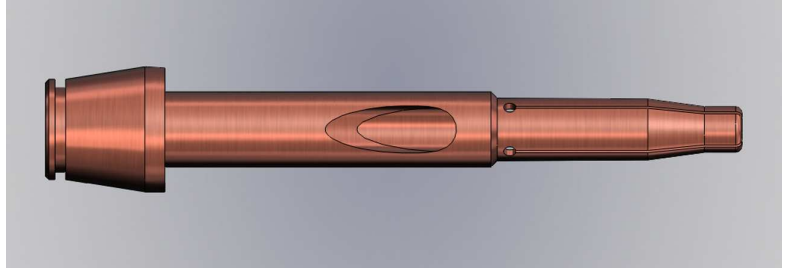

For studs 12 to 20mm long

M3	79-103-103
M4	79-103-104
M5	79-103-105
M6	79-104-106
M8	79-103-108

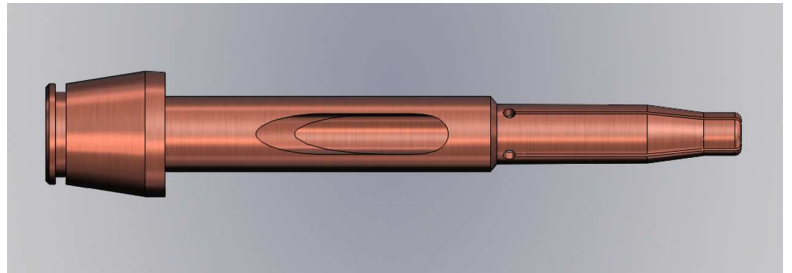

For studs 16 to 35mm long

M3	79-103-123
M4	79-103-124
M5	79-103-125
M6	79-103-126
M8	79-103-128

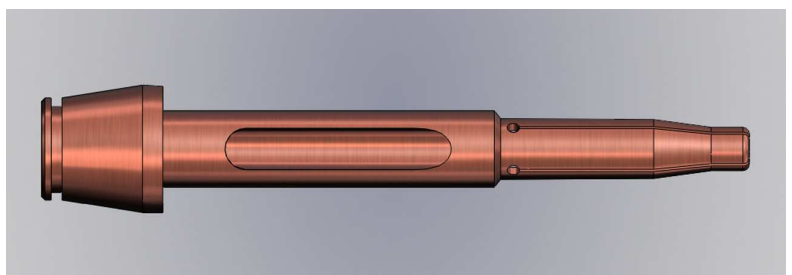

ACCESSORIES

COLLET - 2 PART

Transfer tube for studs 6 to 16mm long

M3	72-103-073
M4	72-103-074
M5	72-103-075
M6	72-103-076
M8	72-103-078

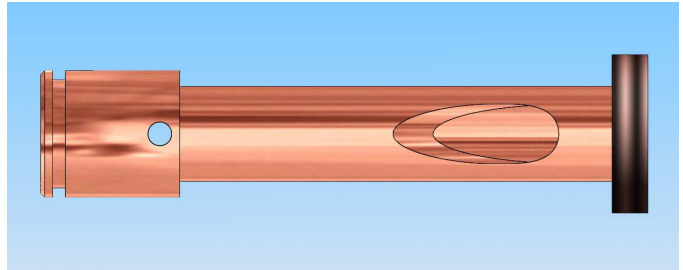

Transfer tube for studs 12 to 20mm long

M3	72-103-063
M4	72-103-064
M5	72-103-065
M6	72-103-066
M8	72-103-068

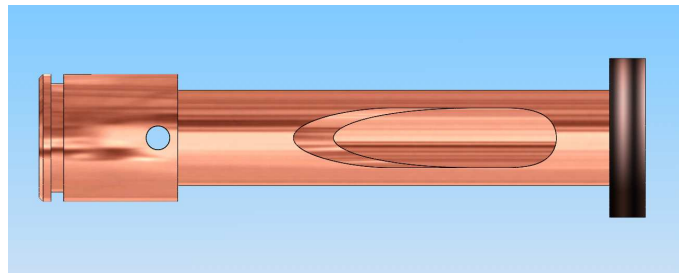

Transfer tube for studs 16 to 35mm long

M3	72-103-083
M4	72-103-084
M5	72-103-085
M6	72-103-086
M8	72-103-088

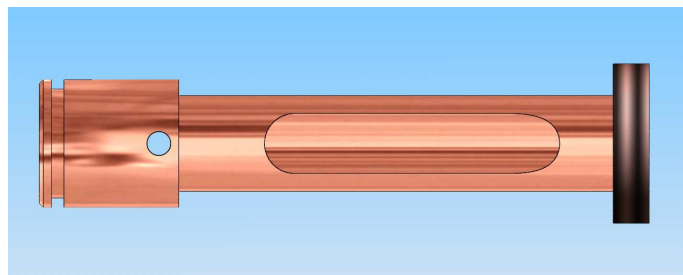

Collet

M3	79-103-003
M4	79-103-004
M5	79-103-005
M6	79-103-006
M8	79-103-008

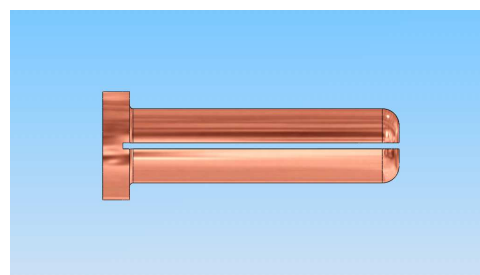

ACCESSORIES

FEED TUBE

Feed tube for studs 6 to 20mm long

M3	72-103-043
M4	72-103-044
M5	72-103-045
M6	72-103-046
M8	72-103-048

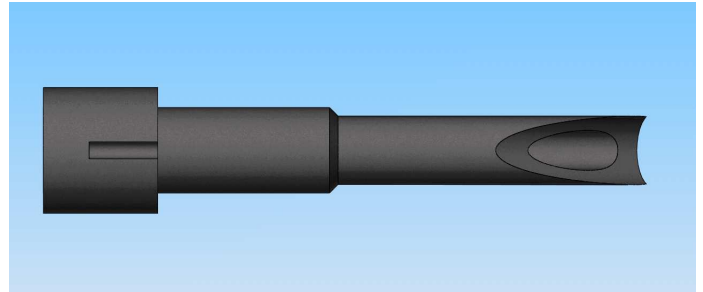

Transfer tubes for studs 16 to 35mm long

M3	72-103-053
M4	72-103-054
M5	72-103-055
M6	72-103-056
M8	72-103-058

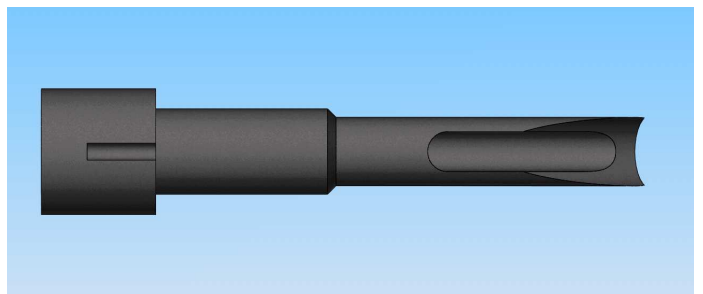

Feed tube gland

M3	72-103-039
M4 to M6	72-103-040
M8	72-103-041

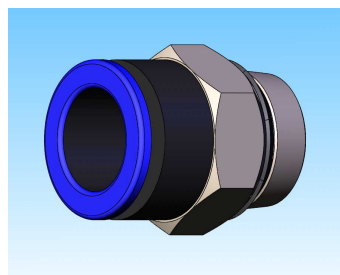

ACCESSORIES

Feed hose

M3	40-20863
M4	40-20871
M5	40-20898
M6	40-20901
M8	40-20928

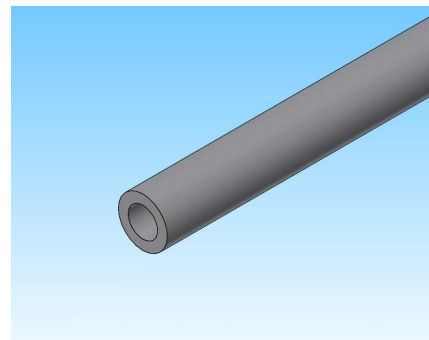

Rod spacer set 72-103-028

To setup the handtool for different length studs, see page 13 (one set is supplied with the handtool).

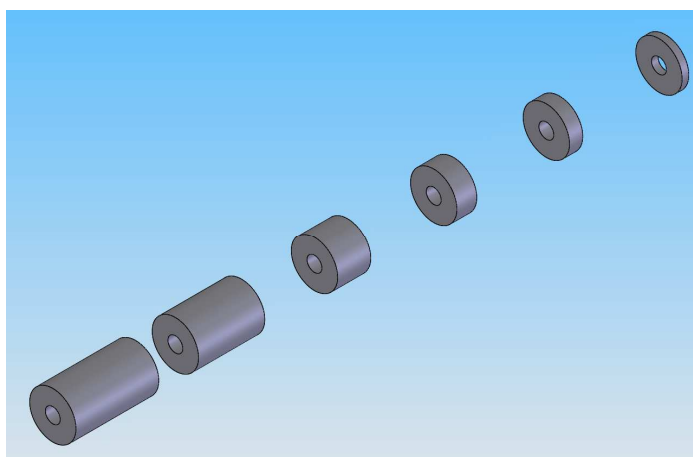

ACCESSORIES

Bellows foot adaptor: for use with inert gas when welding short cycle, or in adverse conditions to protect the handtool from weld spatter.

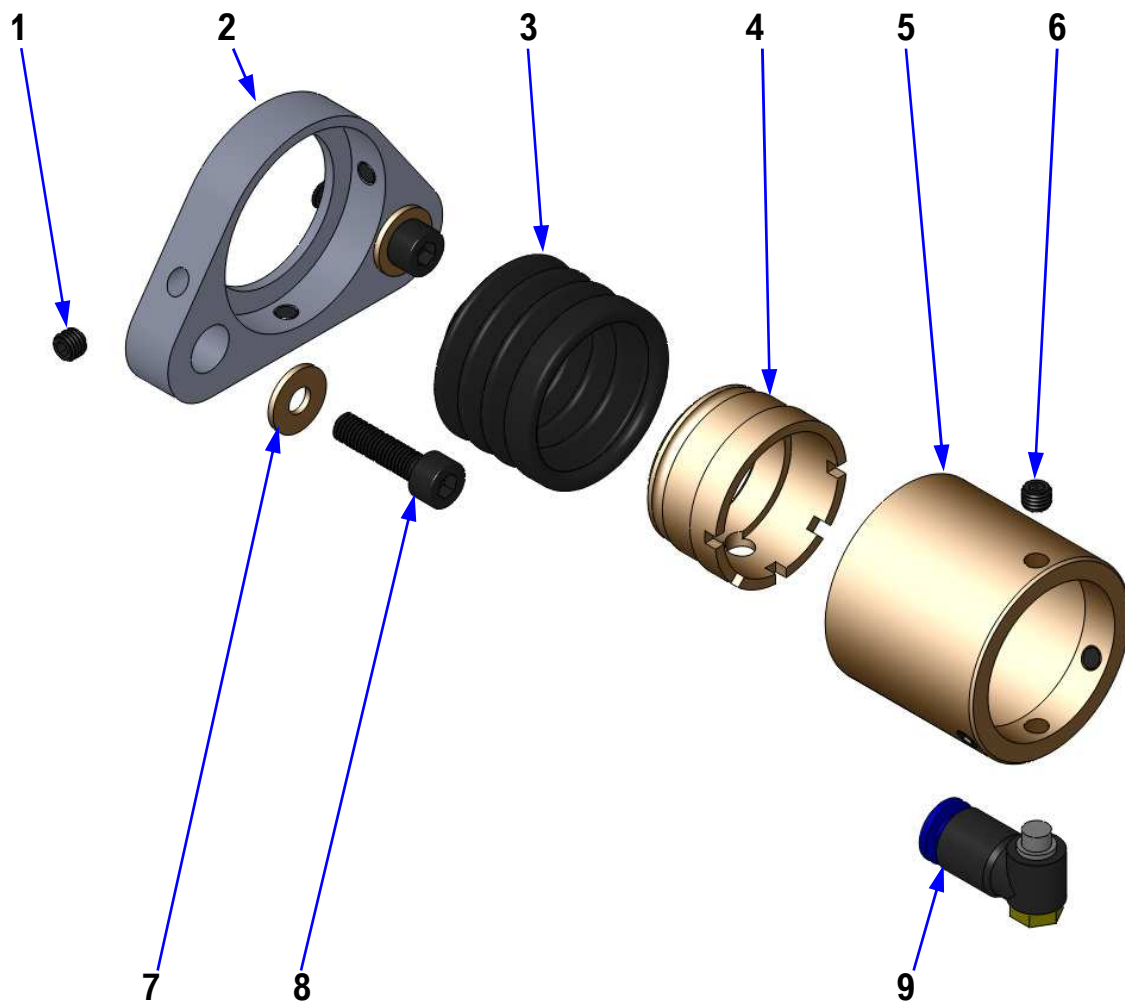

ITEM No	QTY	DESCRIPTION	PART No
1	3	M5 x 4 HEX SKT GRUB SCREW	Z400-05-004
2	1	FOOT ADAPTOR	72-103-182
3	1	BELLOWS	89-101-244
4	1	NOSE CONE	72-103-180
5	1	SLEEVE	72-103-181
6	3	M5 x 4 HEX SKT GRUB SCREW	Z400-05-004
7	2	M5 WASHER	Z605-05-999
8	2	M5 x 20 SKT HEAD CAP SCREW	Z100-05-020
9	1	PNEUMATIC FITTING	71-200-036

Note: if gas is not required replace item 9 with item 1

EC DECLARATION



This is to certify that the machinery listed below is designed and manufactured in conformance with all applicable health and safety regulations.

This statement is invalid if any modifications are carried out on the machinery without the prior written approval of Taylor Studwelding Systems Ltd

Applicable EC guidelines and corresponding standards:

Low voltage guideline 73/23/EEC:

EN60204-1 Safety of machinery - Electrical equipment of machines

EMC guidelines 89/336/EEC (electromagnetic compatibility):

EN50081 Electromagnetic compatibility - Generic emission standard

EN50082 Electromagnetic compatibility - Generic immunity standard

EN50199 Electromagnetic compatibility (EMC) Product standard for Arc welding equipment

Machine guidelines 89/392/EEC:

EN60974-1 Arc welding equipment: Electromagnetic compatibility (EMC) requirements

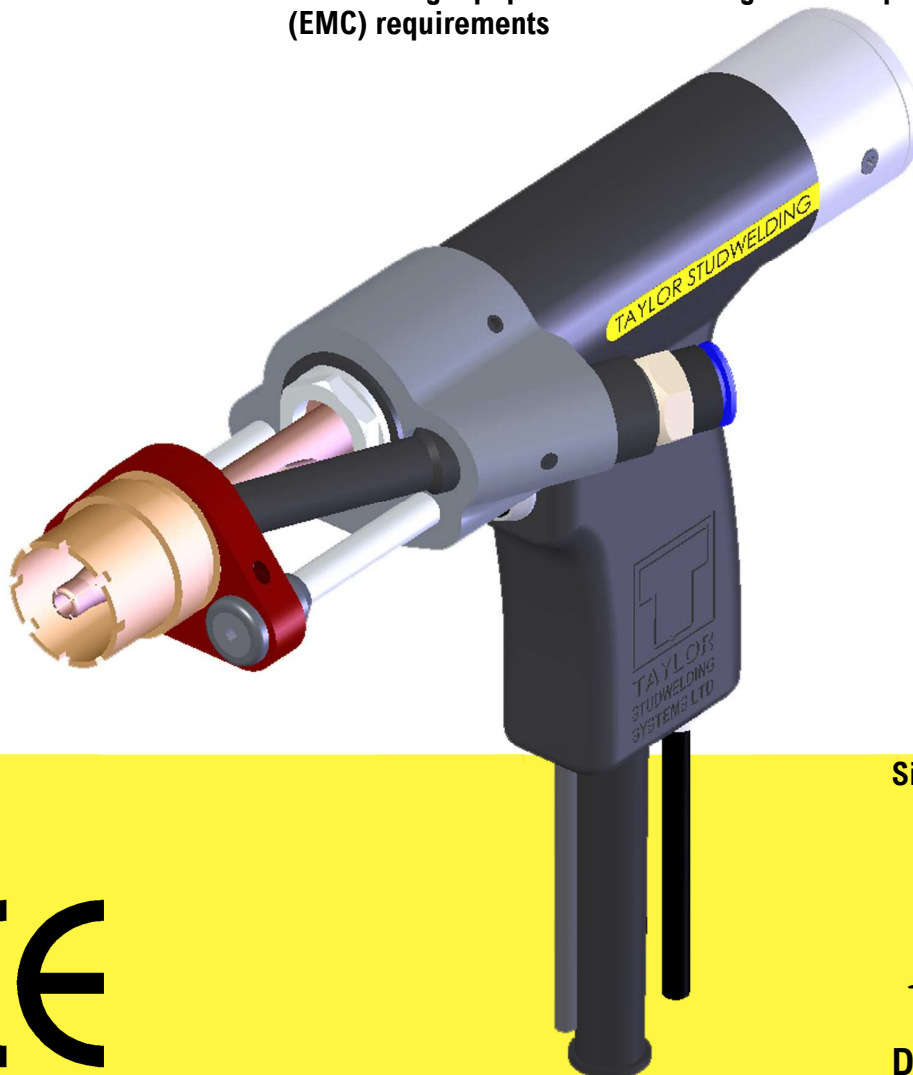
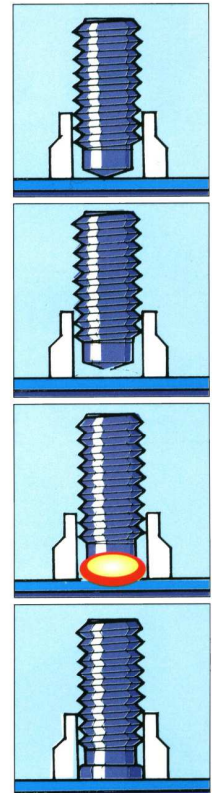

Signed

A handwritten signature in black ink, appearing to read 'D. Taylor'.

D. Taylor
Managing Director



A TAYLORMADE AUTOFEED STUDWELDING SYSTEM FOR CD AND SHORT CYCLE STUDS